

FURUNO

OPERATOR'S MANUAL

SATELLITE COMPASS

Model

SC-33

IMPORTANT NOTICES

General

- This manual has been authored with simplified grammar, to meet the needs of international users.
- The operator of this equipment must read and follow the descriptions in this manual. Wrong operation or maintenance can cancel the warranty or cause injury.
- Do not copy any part of this manual without written permission from FURUNO.
- If this manual is lost or worn, contact your dealer about replacement.
- The contents of this manual and equipment specifications can change without notice.
- The example screens (or illustrations) shown in this manual can be different from the screens you see on your display. The screens you see depend on your system configuration and equipment settings.
- Save this manual for future reference.
- Any modification of the equipment (including software) by persons not authorized by FURUNO will cancel the warranty.
- The following concern acts as our importer in Europe, as defined in DECISION No 768/2008/EC.
 - Name: FURUNO EUROPE B.V.
 - Address: Ridderhaven 19B, 2984 BT Ridderkerk, The Netherlands
- All brand and product names are trademarks, registered trademarks or service marks of their respective holders.

How to discard this product

Discard this product according to local regulations for the disposal of industrial waste. For disposal in the USA, see the homepage of the Electronics Industries Alliance (<http://www.eiae.org/>) for the correct method of disposal.

How to discard a used battery

Some FURUNO products have a battery(ies). To see if your product has a battery, see the chapter on Maintenance. Follow the instructions below if a battery is used. Tape the + and - terminals of battery before disposal to prevent fire, heat generation caused by short circuit.

In the European Union

The crossed-out trash can symbol indicates that all types of batteries must not be discarded in standard trash, or at a trash site. Take the used batteries to a battery collection site according to your national legislation and the Batteries Directive 2006/66/EU.



In the USA

The Mobius loop symbol (three chasing arrows) indicates that Ni-Cd and lead-acid rechargeable batteries must be recycled. Take the used batteries to a battery collection site according to local laws.

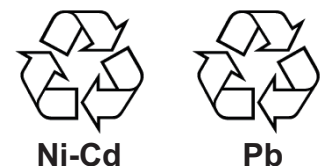

In the other countries

There are no international standards for the battery recycle symbol. The number of symbols can increase when the other countries make their own recycle symbols in the future.



SAFETY INSTRUCTIONS



WARNING

Indicates a potentially hazardous situation which, if not avoided, could result in death or serious injury.



CAUTION

Indicates a potentially hazardous situation which, if not avoided, can result in minor or moderate injury.



Warning, Caution



Prohibitive Action



Mandatory Action

Safety instructions for the operator



WARNING



Do not open the equipment.

Only qualified personnel should work inside the equipment.



Do not disassemble or modify the equipment.

Fire, electrical shock or serious injury can result.

Warning Label

A warning label is attached to the equipment. Do not remove the label. If the label is missing or illegible, contact a FURUNO agent or dealer about replacement.



Name: Warning Label(1)
Type: 86-003-1011-3
Code No.: 100-236-233-10

Safety instructions for the installer



WARNING



Turn off the power at the switchboard before beginning the installation.

Fire or electrical shock can result if the power is left on.



Be sure that the power supply is compatible with the voltage rating of the equipment.

Connecting an incompatible power supply can cause fire or damage the equipment. The voltage rating appears on the inlet of power.



CAUTION



Observe the following compass safe distances to prevent interference to a magnetic compass:

	Standard compass	Steering compass
SC-33	0.45 m	0.40 m



Do not use high-pressure cleaners to clean this equipment.

This equipment has the waterproof rating outlined in the specifications, at the back of this manual. However, the use of high-pressure cleaning equipment can cause water ingress, resulting in damage to, or failure of, the equipment.

TABLE OF CONTENTS

FOREWORD	iv
SYSTEM CONFIGURATION	v
1. MOUNTING	1
1.1 Equipment Lists.....	1
1.2 Mounting Considerations	3
1.3 Mounting Procedure.....	8
2. WIRING	10
2.1 NMEA 2000 Network Connection	10
2.2 NMEA 0183 Network Connection	11
2.2.1 How to connect the Cable Assembly (FRU-NMEA-NFF-R15/30).....	11
2.2.2 How to connect the Cable Replacement Kit (OP20-50)	12
2.2.3 How to secure and waterproof the cable connections.....	15
3. ADJUSTMENTS	16
3.1 Initial Setting Menu.....	16
4. NMEA 2000 I/O DATA	21
4.1 Input Data.....	21
4.2 Output Data.....	22
5. MAINTENANCE, TROUBLESHOOTING	25
5.1 Preventive Maintenance.....	25
5.2 Troubleshooting	25
MENU TREE	AP-1
WHAT IS SBAS?	AP-5
SPECIFICATIONS	SP-1
PACKING LISTS	A-1
OUTLINE DRAWING	D-1
INTERCONNECTION DIAGRAM	S-1

FOREWORD

A Word to the Owner of the SC-33

Congratulations on your choice of the FURUNO SC-33 Satellite Compass. We are confident you will see why the FURUNO name has become synonymous with quality and reliability.

Since 1948, FURUNO Electric Company has enjoyed an enviable reputation for quality marine electronics equipment. This dedication to excellence is furthered by our extensive global network of agents and dealers.

This equipment is designed and constructed to meet the rigorous demands of the marine environment. However, no machine can perform its intended function unless installed properly. Please carefully read and follow the recommended procedures for installation.

Thank you for considering and purchasing FURUNO equipment.

Features

The SC-33 Satellite Compass outputs highly accurate heading, GNSS position data and speed and motion data for AIS, Tracked Target (TT) radar, autopilots, etc. Data is output in NMEA 2000[®] (NMEA2000 is a trademark of National Marine Electronic Association (the United States)) format, and with connection of the optional interface unit the data can be converted to NMEA 0183 format. Setting time is within three minutes and the follow-up performance is an excellent 45°/s.

- Heading accuracy of 0.4° RMS
- Perfect heading sensor for radar/TT, AIS, scanning sonar, etc.
- Outputs accurate heading, position, time, speed, course.
- Pitch and roll output in digital format for ship's motion correction
- A new Satellite Compass™ designed with FURUNO advanced GNSS kinematic technology.
- Data can be output in NMEA 2000 format
- Free from regular maintenance
- Aesthetically pleasing antenna fits nicely on recreational boats
- Outputs acceleration speed and angular velocity at installation

Software used in this product

This equipment uses the following open source software.

This product includes software to be licensed under the GNU General Public License (GPL) version 2.0, GNU Lesser General Public Software License (LGPL) version 2.0, Apache, BSD and others. The program(s) is/are free software(s), and you can copy it and/or redistribute it and/or modify it under the terms of the GPL version 2.0 or LGPL version 2.0 as published by the Free Software Foundation. Please access to the following URL if you need source codes.

https://www.furuno.co.jp/en/contact/cnt_oss_e01.html

Program No.

OS : 2051593-01.**

APL : 2051594-01.**

GNSS: 48505230**

** denotes minor modifications.

SYSTEM CONFIGURATION

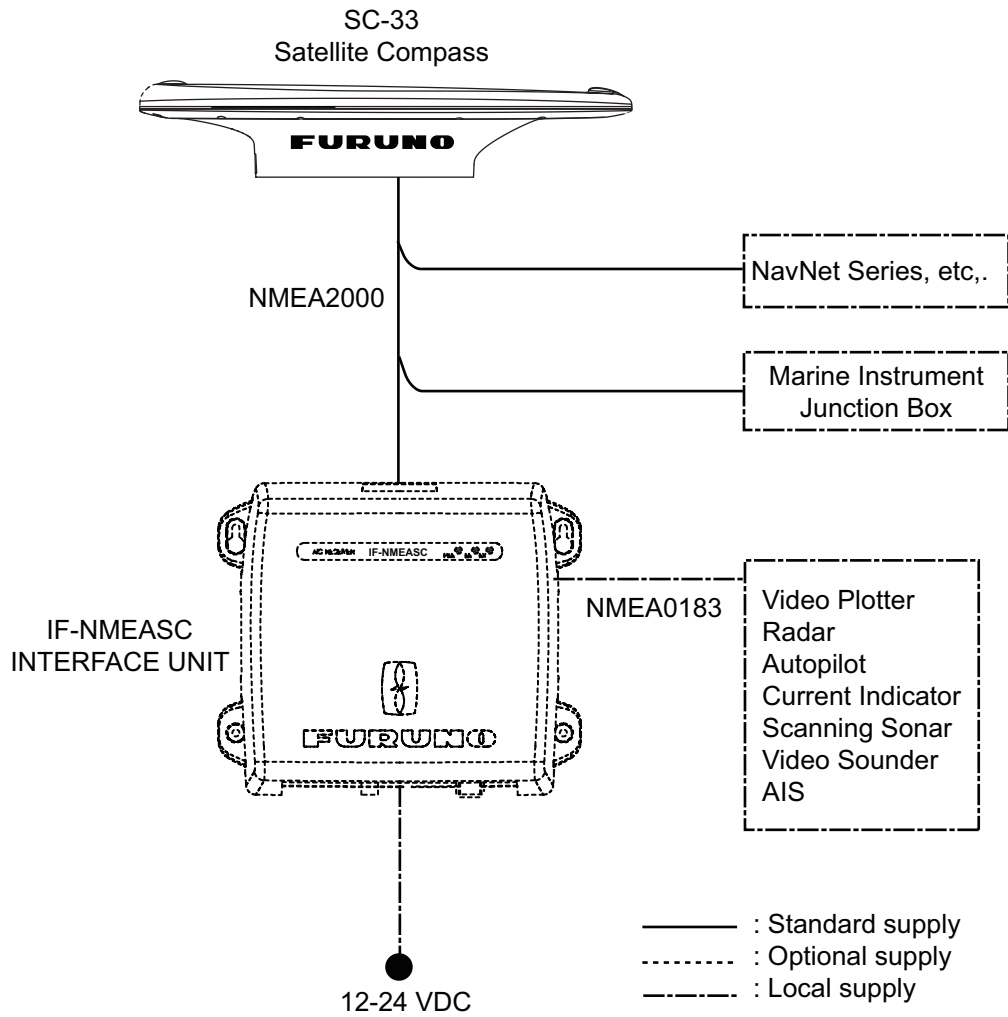

1. MOUNTING

1.1 Equipment Lists

Standard supply

Name	Type	Code No.	Qty	Remarks
Satellite Compass	SC-33	-	1	
Installation Materials	CP20-04400	000-035-094	1 (Select)	For NavNet Series, etc., With cable FRU-NMEA-PMMFF-060 (6 m) and Installation materials CP20-04401
	CP20-04410	000-035-095		For connecting IN-NMEASC, With cable FRU-NMEA-NFF-R15 (15 m) and Installation materials CP20-04401
	CP20-04401	001-508-130		No cable

* See packing list at back of manual for details.

Optional supply

Name	Type	Code No.	Remarks
Interface Unit	IF-NMEASC	-	See OME-72651-x attached to the Interface Unit.
Cable Assembly	FRU-NMEA-NFF-R15	001-507-080	For IF-NMEASC, 15m, ϕ 6.7
	FRU-NMEA-NFF-R30	001-507-090	For IF-NMEASC, 30m, ϕ 6.7
Cable Conversion kit	OP20-50	001-506-810	Replacement kit for SC-30 (MJ-A10SPF0015-xxxC) <u>Contents</u> - Waterproof relay box (JPBS 06) - 120 Ω Lead resistance (03S9939) - FRU-NMEA-PFF-060 - Vinyl tape (0.2X19X10000MM Black, 000-172-691-10) - Self-bonding tape (No.15, 000-174-646-10)
Bird-Repellent Fixture	OP20-36	004-380-830	Four pieces
	OP20-37	004-380-840	Single
Cable for NMEA2000 (Micro)	FRU-NMEA-PMMFF-010	001-506-820	w/connectors (Light), 1m
	FRU-NMEA-PMMFF-020	001-506-830	w/connectors (Light), 2m
	FRU-NMEA-PMMFF-060	001-507-000	w/connectors (Light), 6m
	FRU-NMEA-PFF-010	001-507-010	w/connector (Light), 1m
	FRU-NMEA-PFF-020	001-507-030	w/connector (Light), 2m
	FRU-NMEA-PFF-060	001-507-040	w/connector (Light), 6m
Connector for NMEA2000	FRU-MM1MF1MF1001	001-507-050	T-Connector, Micro Style: 3
	FRU-MF000000001	001-507-060	Micro Style, female, termination resistor
	FRU-MM100000001	001-507-070	Micro Style, male, termination resistor

1.2 Mounting Considerations

In addition to the considerations described in this section, keep the length of the satellite compass cable in mind when selecting a mounting location.

General considerations

Mount the satellite compass above radar mast

As shown in the figure below, mount the SC-33 satellite compass above a radar mast. This provides an unobstructed path between the satellite compass and the satellite, regardless of vessel heading. Follow the procedure on the next page to choose an installation site.

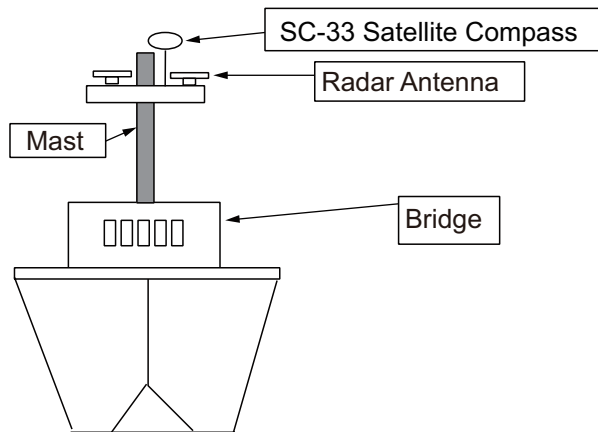

Satellite compass mounted above antennas and structures

If satellite compass cannot be installed above radar mast

If absolutely impossible to do otherwise, the satellite compass may be installed below a radar mast. However, certain guidelines must be followed to prevent the shading and multipath problems which occur as shown in the figure below. Follow the procedure on the next page to choose an installation site.

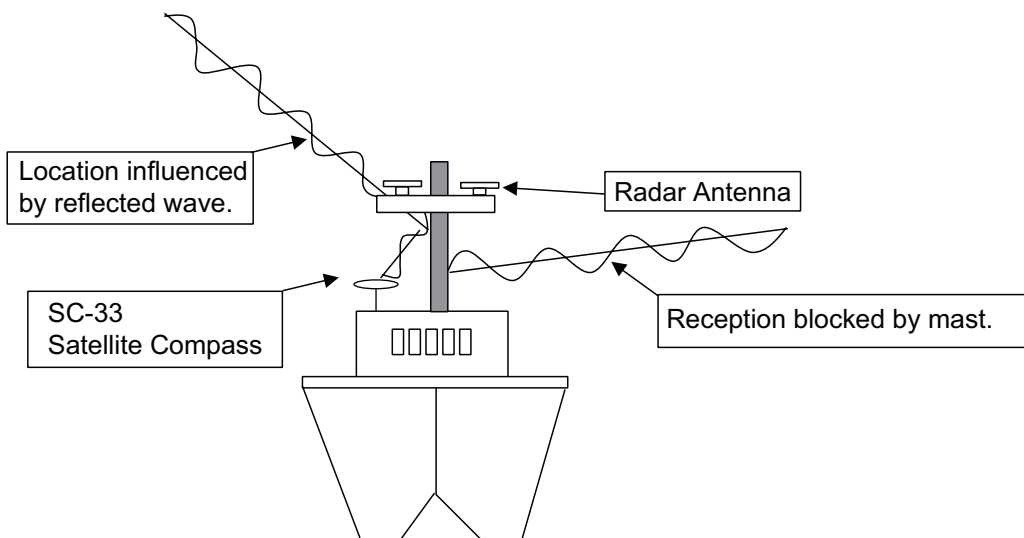

Problems associated with mounting satellite compass below a radar mast

Selecting the installation site

The installation site must satisfy the four conditions described in this section. After choosing the site, determine installation height, following the procedure in the next section.

CONDITION 1: Locate the SC-33 away from masts that might prevent reception of the GNSS signal

- Install the satellite compass where the field of view against zenith is at least $\pm 85^\circ$. The installation site should be as high as possible, above masts, etc. which might interfere with reception.

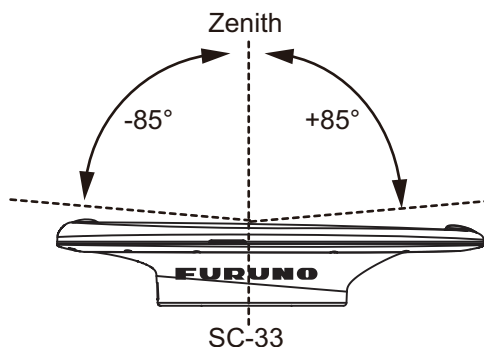

- If the above condition cannot be satisfied, separate the satellite compass so that the horizontal angle to the interfering object is less than 10° . Refer to the table below to determine minimum separation distance.

Mast diameter	Min. separation distance
10 cm	1.5 m
30 cm	3 m

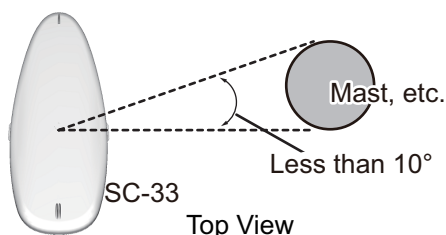

CONDITION 2: Locate the SC-33 out of radar beams

- Locate the SC-33 more than 20° above the top of a radar antenna.
- Separate the SC-33 at least 3 m from an open-type radar antenna.
- If the SC-33 cannot be separated at least 3 meter from an open-type radar antenna, install it at least 80 cm above the top of the radar antenna.

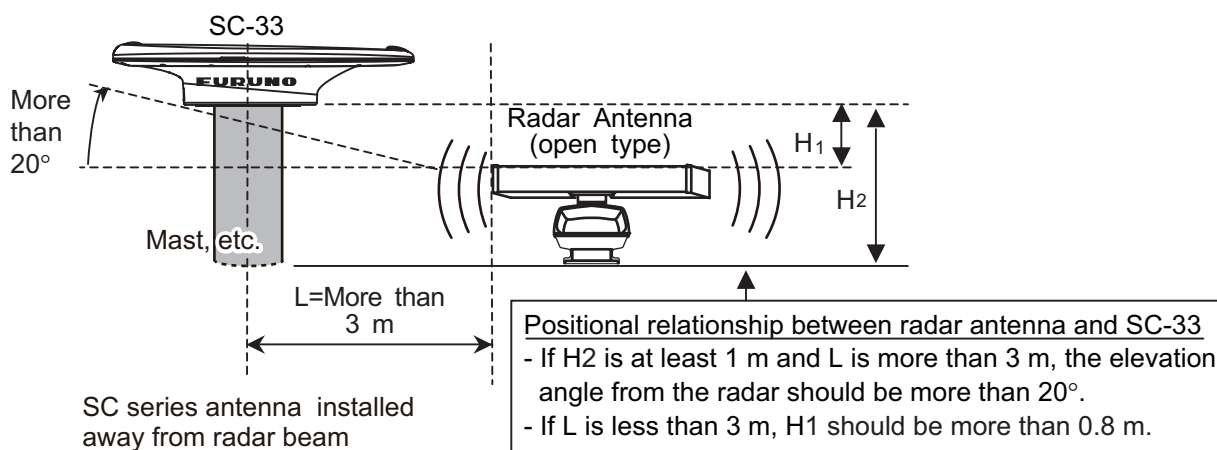

Separation distances from radar antenna

1. MOUNTING

CONDITION 3: Locate the SC-33 out of Inmarsat

Separate the SC-33 from an Inmarsat Fleet Broadband Antenna by at least 3 m.

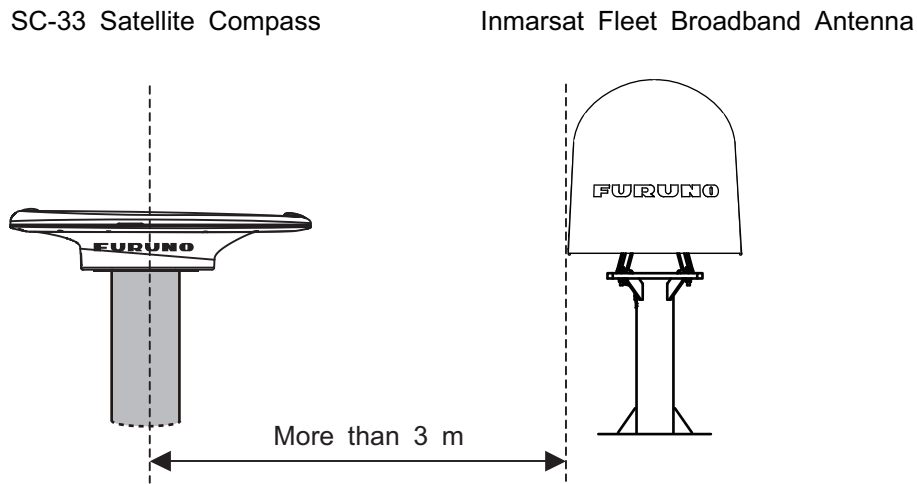

Separation distance from Inmarsat Fleet Broadband Antenna

CONDITION 4: Locate the SC-33 away from communication (VHF, etc.) antennas

Separate the SC-33 as far as possible from communication antennas.

CONDITION 5: Select a stable location with minimal or no vibrations from engines or waves

Install the SC-33 in a stable location. The SC-33 contains highly sensitive GNSS and angular speed sensors. Therefore, try to install it where shock, vibration, etc. are minimal.

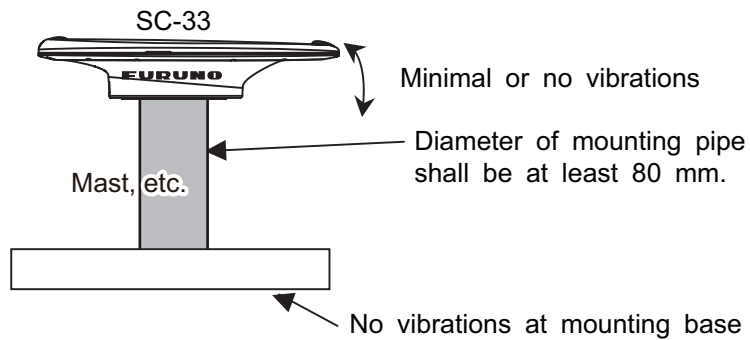

Installation height

After choosing the installation site, determine the installation height, considering composition of the deck and surrounding area.

The deck is flat and metallic, or the area around the installation site is metallic

- If metallic surface is wider than the area of the top view of the SC-33, install the SC-33 at least 800 mm above the deck.

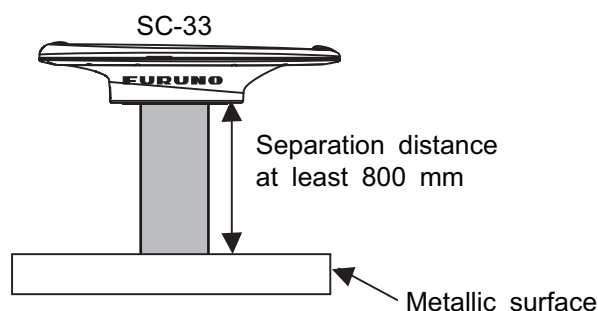

The deck is non-metallic (FRP, etc.) and there are no metallic objects around the installation site

- If mounting surface is non-metallic and there is no radar or Inmarsat antenna in the vicinity, mount the SC-33 directly on the non-metallic surface. This can be done provided the metallic material support is smaller than the SC-33. If the SC-33 is to be fixed to a mounting pipe, choose a site where there is less vibration.

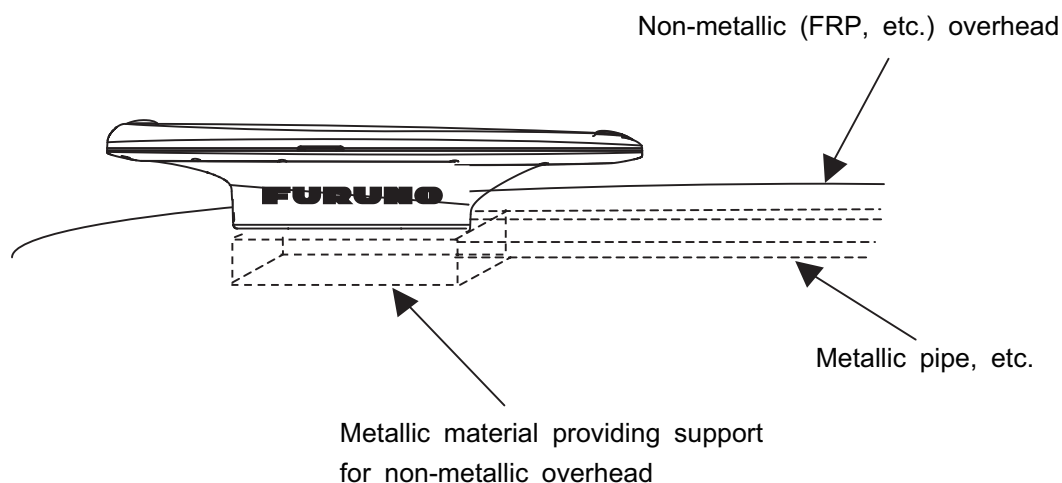

1. MOUNTING

Installation examples for a pleasure boat

No tuna tower

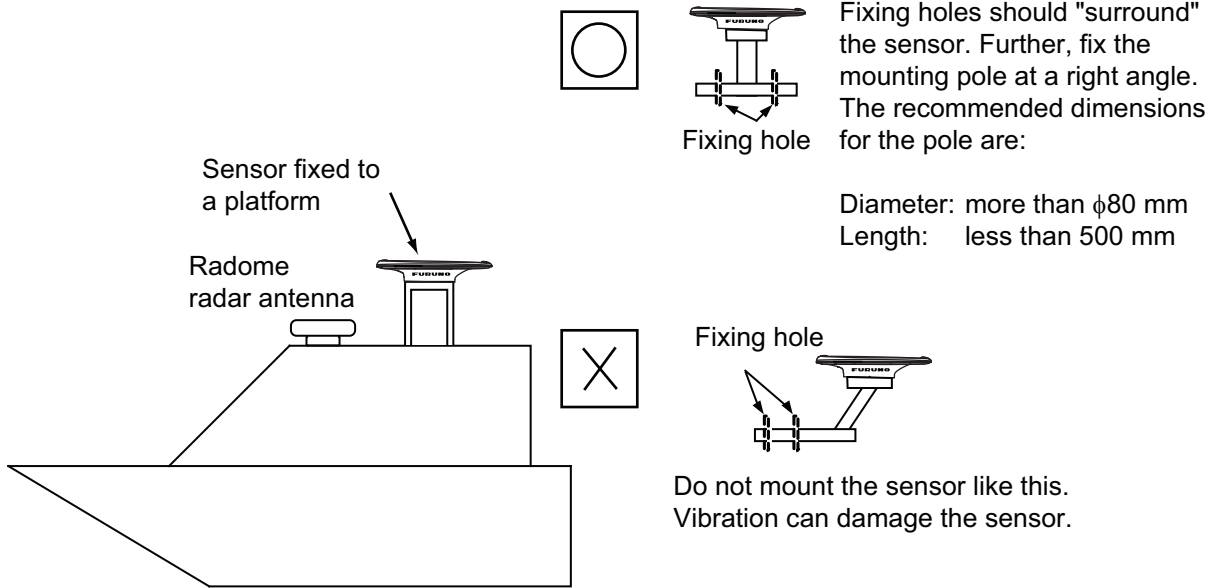

With tuna tower

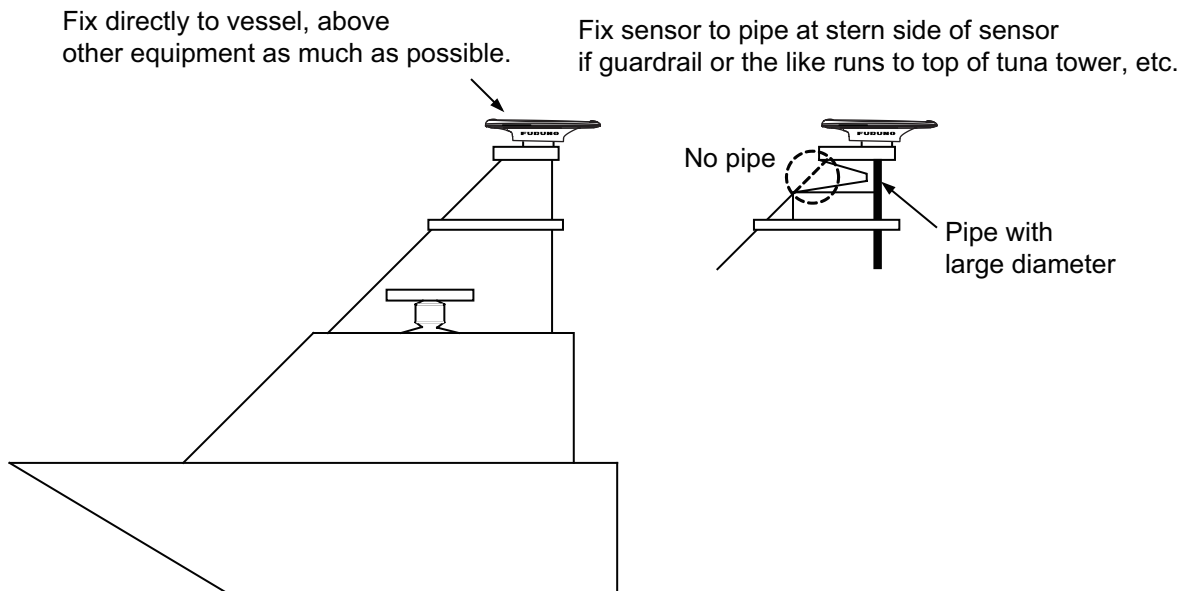

1.3 Mounting Procedure

Note 1: The bird-repellent fixtures (optional supply) can be attached to the antenna cover to prevent birds from landing on the cover. If it is more convenient to attach the bird-repellent fixtures before securing the antenna unit to the mounting location, do step 6 below before fixing the antenna unit.

Note 2: According to the installation location, connecting the antenna pig tail connector to the NMEA2000 bus or a cable from an optional unit in advance is easy to fix to the location. Connect a cable with reference to step 5 beforehand. Then, waterproof the connection.

1. As shown in the figure below, weld a platform (local supply) for which to mount the satellite compass. The thickness of the platform should be 5 mm to 15 mm.

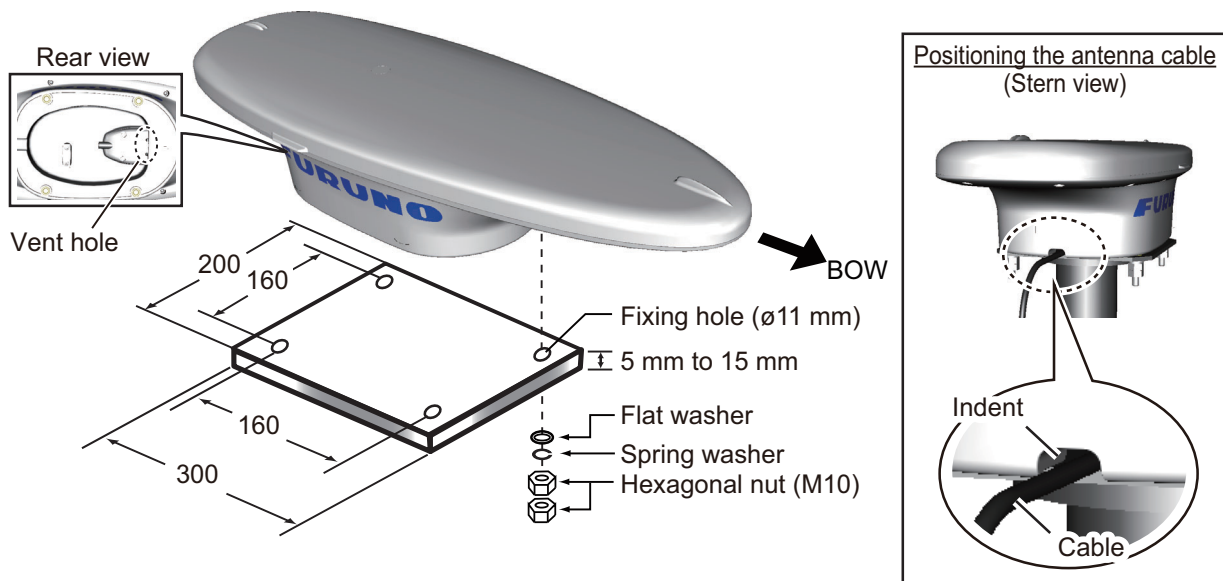

2. Orient the antenna unit to face the bow, referring to the figure above. The antenna should be installed within $\pm 2.5^\circ$ of the bowline.
 - Note 1:** Take care not to crush the cabling when mounting the antenna to the platform.
 - Note 2:** Take care not to cover the vent hole on the antenna.
3. Secure the unit to the platform with four sets of M10 hex. nuts, spring washers and flat washers (all included as installation materials) with 20 ± 2 N•m torque.

How to fasten double nuts

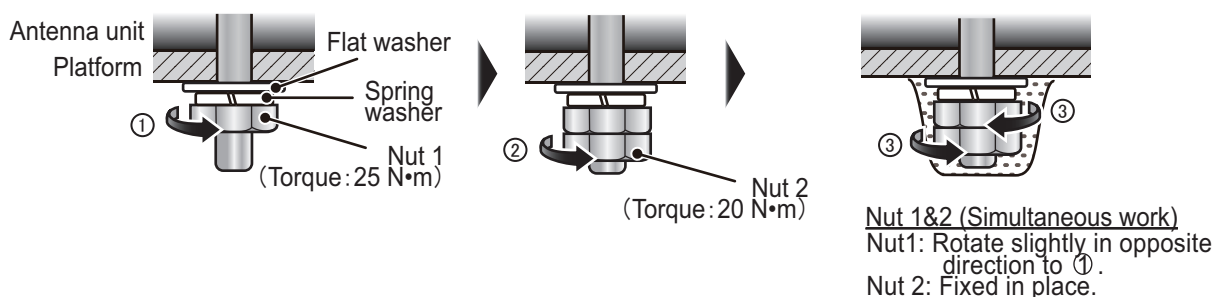

1. MOUNTING

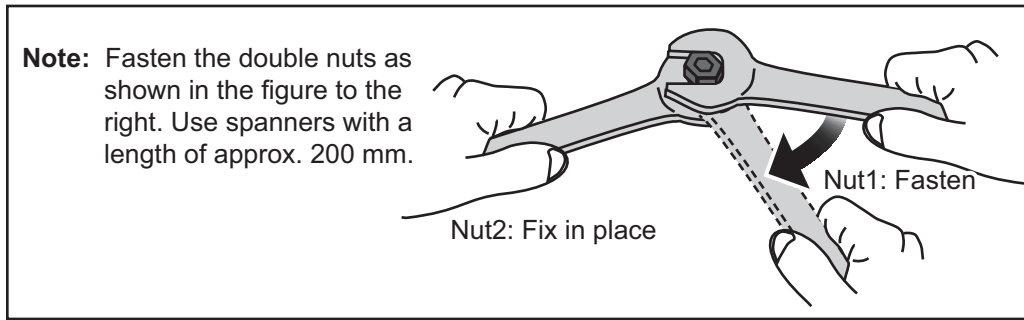

4. Coat the exposed parts of the nuts, bolts and washers with the Adhesive TB5211 (included) to prevent corrosion.

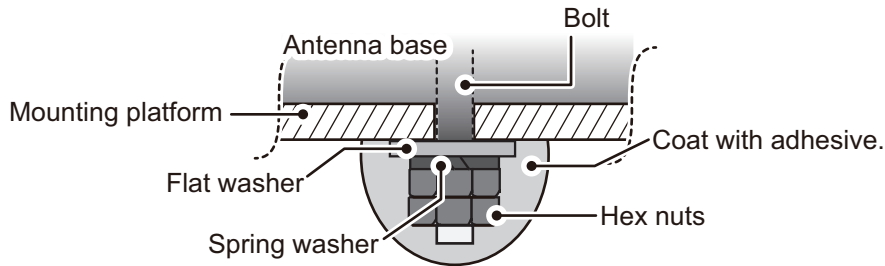

5. Connect the antenna pig tale connector to the NMEA2000 bus or a cable from the optional unit, then waterproof the connection. See chapter 2 for the wiring and the waterproofing.
6. Remove the double-sided tape from the optional bird-repellent fixtures, then attach to the antenna cover. Coat around the bird-repellent fixtures with the Adhesive TB5211 (included).



7. Fix the satellite compass cable to the pipe at suitable intervals with the cable ties (local supply).

Note: Create a loop in the cable close to the satellite compass and tie the loop with a cable tie for maintenance work, as shown in the below figure.



Create a loop of more than 15 cm in diameter (approx. twice the length of a pigtail connector) so that the loop does not put stress on the pigtail connector.

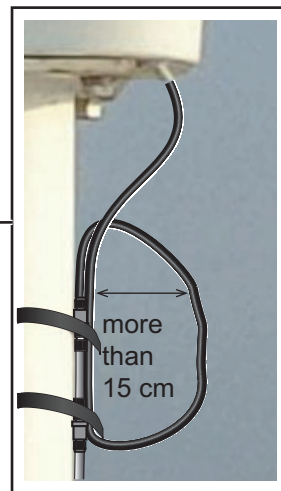

2. WIRING

Attention

- Do not loop the antenna cable.
- Do not bundle the SC-33 cable with radio equipment cables.
- When the above noise reductions are insufficient, adjust the squelch on the radio equipment.

2.1 NMEA 2000 Network Connection

Using the supplied cable assembly, connect the SC-33 pigtail cable (Micro style connector) to the NMEA2000 network backbone.

The SC-33 connects to the devices in an NMEA 2000 network with a drop cable, which is connected to a backbone cable w/T-type connectors. The backbone cable can be light or heavy type. Attach a terminator at both ends of the backbone cable. Use a Micro-C connector to connect to the devices. We recommended that power from the NMEA 2000 network be input at the center of the backbone cable. For connection to the IF-NMEA SC Interface Unit, see its operator's manual.

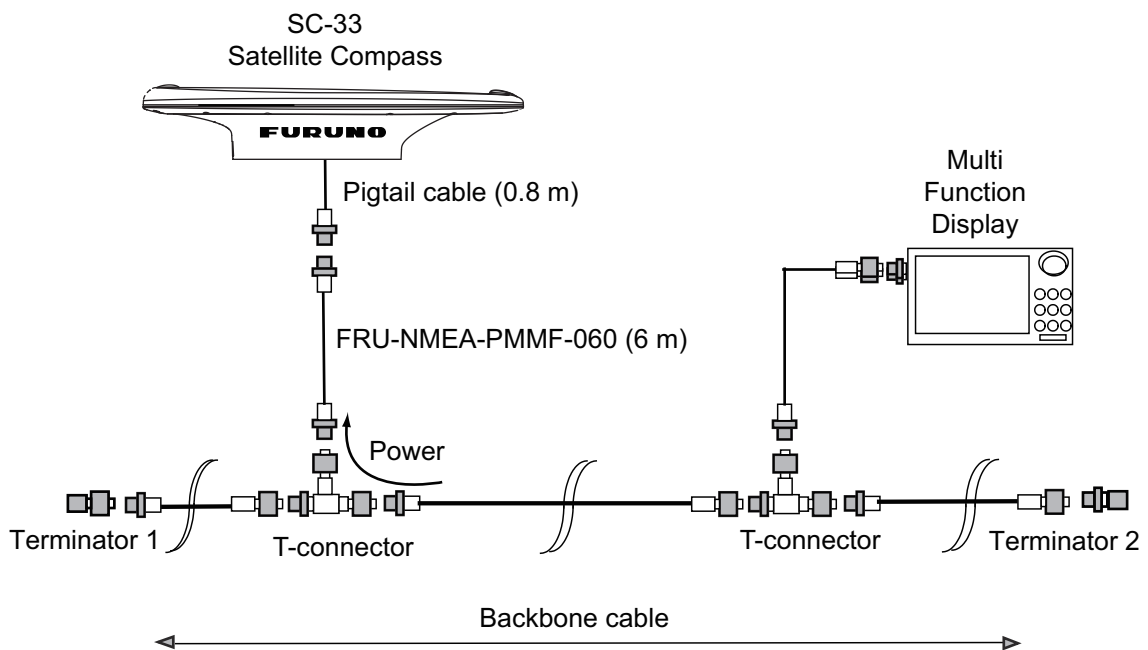

What is NMEA 2000 (CAN) bus?

CAN bus is a communication protocol (NMEA2000 compliant) that shares multiple data and signals through a single backbone cable. You can simply connect any CAN bus devices onto the backbone cable to expand your network on-board. With CAN bus, IDs are assigned to all the devices in the network, and the status of each sensor in the network can be detected. All the CAN bus devices can be incorporated into the CAN bus network. For detailed information about CAN bus wiring, see "Furuno CAN bus Network Design Guide" (Type: TIE-00170) on Tech-Net.

2. WIRING

Guideline for Connecting

Follow these guidelines when selecting a mounting location.

- Where the cable connectors and CAN bus/NMEA2000 connectors are subjected to moisture or water spray, waterproof the connectors as shown below.
 1. Wrap the connection point with a single layer of vinyl tape.
 2. Wrap one layer of self-bonding tape over the vinyl tape.
 3. Wrap two layers of vinyl tape over the self-bonding tape.

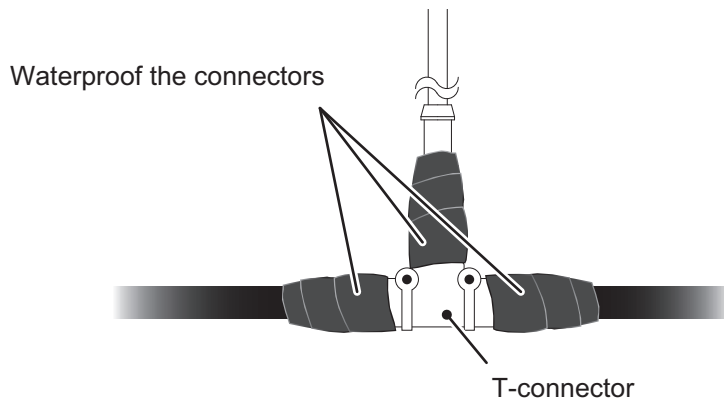

2.2 NMEA 0183 Network Connection

Optional interface unit IF-NMEASC is required when connecting with NMEA0183 equipment. For IF-NMEASC, see the Operator's Manual of the IF-NMEASC.

2.2.1 How to connect the Cable Assembly (FRU-NMEA-NFF-R15/30)

The installation of the other terminal connector and T-connector is not required because the FRU-NMEA-NFF-R15/30 is the terminal resistance internal cable of 120 ohm.

Securing and waterproofing connections

- Where the cable connectors and CAN bus/NMEA2000 connectors are subjected to moisture or water spray, waterproof the connectors as shown below.
 1. Wrap the connection point with a single layer of vinyl tape.
 2. Wrap one layer of self-bonding tape over the vinyl tape.
 3. Wrap two layers of vinyl tape over the self-bonding tape.

STEP 1

Wrap connection in self-bonding tape for waterproofing.

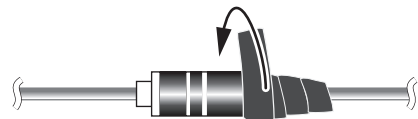

STEP 2

Wrap the self-bonding tape with vinyl tape, covering approx. 50 mm of the connecting cable. Bind the tape ends with cable cable ties to prevent the tape from unraveling.



2.2.2 How to connect the Cable Replacement Kit (OP20-50)

Use a waterproof relay box (JPBS06) to relay connection when connecting to the SC-33 with the MJ-A10SPF0015-150C/300C cable used in SC-30.

- 1) Unfasten four washer head screws on the top of the waterproof relay box to remove the cover.



- 2) Fabricate the MJ-A10SPF0015-150C/300C as follows.

- 1) Cut the MJ-10 connector part. Expose inner vinyl sheath by approx. 40 mm. Be careful not to damage inner shield and cores.

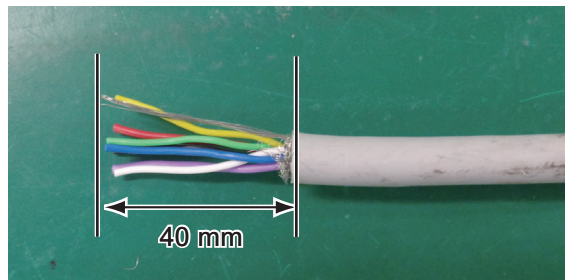

- 2) Cut unused wires (green, yellow and purple) to approx. 10 mm, then isolate them with vinyl tape. Wrap the drain wire with a vinyl tube.

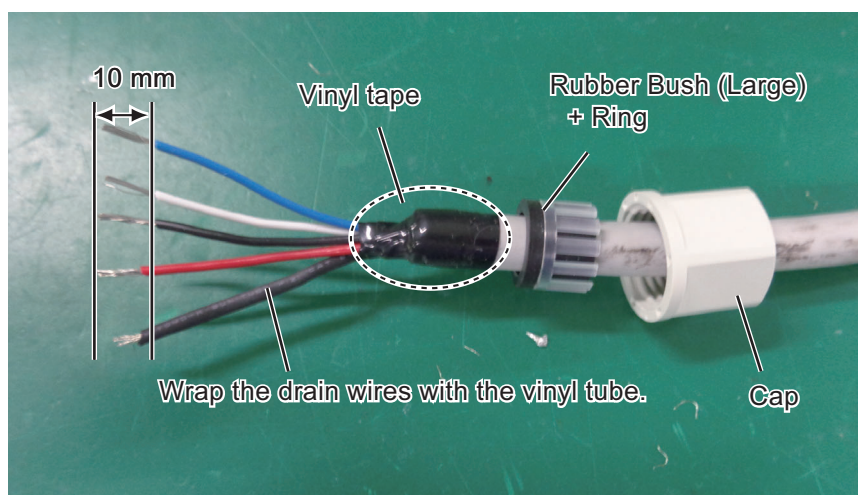

Note: Make sure the rubber bush and ring are oriented correctly (as shown in the figure above).

2. WIRING

3) Fabricate the FRU-NMEA-PFF-060 cable as follows.

- 1) On the end of the side without the FRU connector, cut into the one end part of the FRU connector. Expose inner vinyl sheath by approx. 40 mm. Be careful not to damage inner shield and cores.

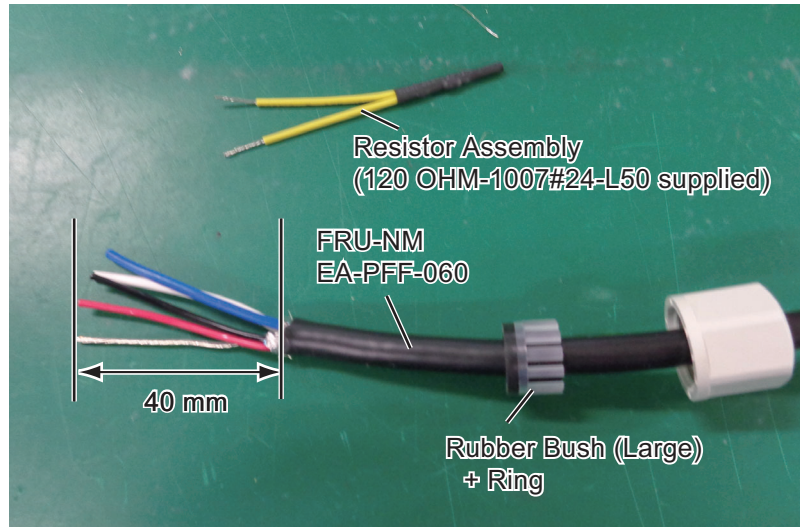

- 2) Wrap the drain wire with a vinyl tube.

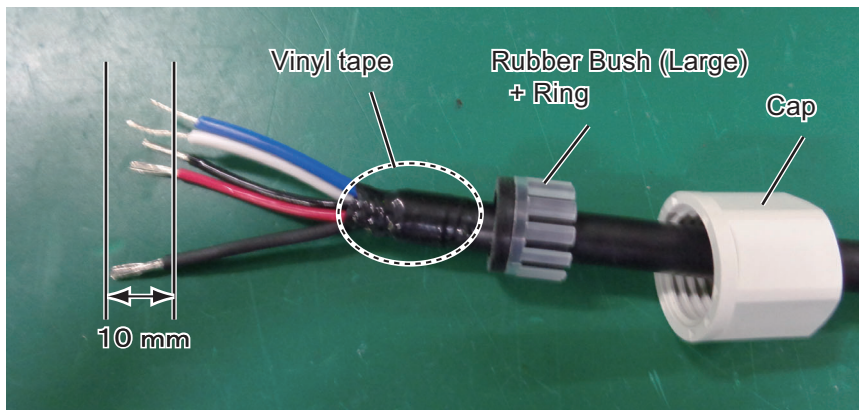

Note: Make sure the rubber bush and ring are oriented correctly (as shown in the figure above).

- 3) Twist the blue and white core wires and a resistor assembly, and attach a closed-end lug to the wires.

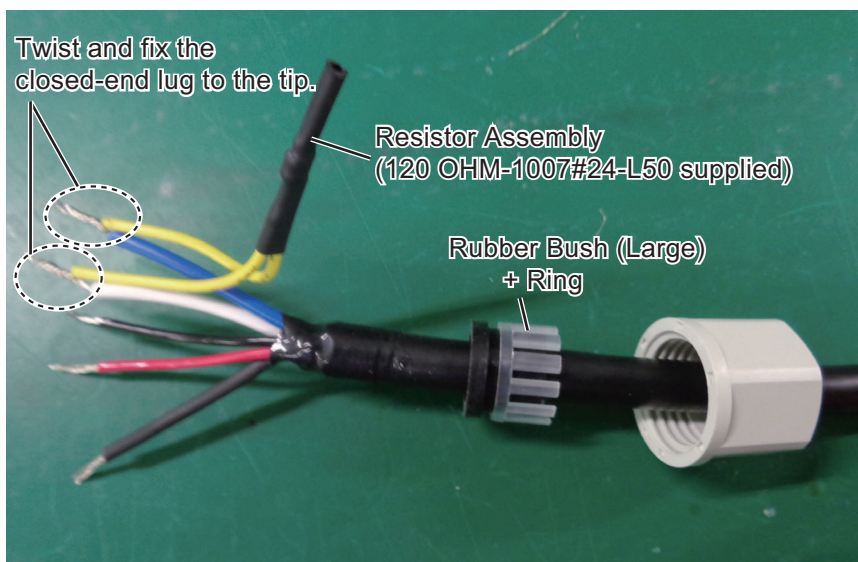

- 4) Connect the cables to the waterproof relay box.
Connect the CAN cable (FRU-NMEA-PFF-060) included to the cable replacement kit and the cable for SC-30 (MJ-A10SPF0015-150C/300C) to the internal terminal box.

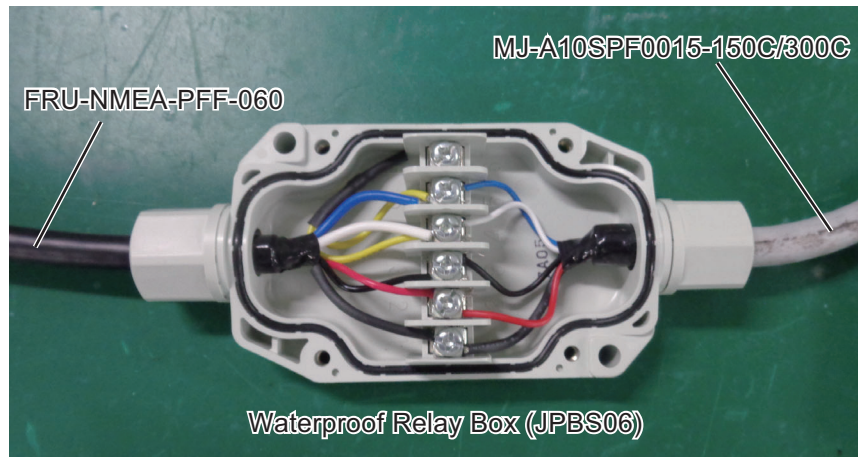

- 5) Fit the rubber bush, ring and cap, in that order. Make sure the order is as shown in the below figure, to keep the IP rating.

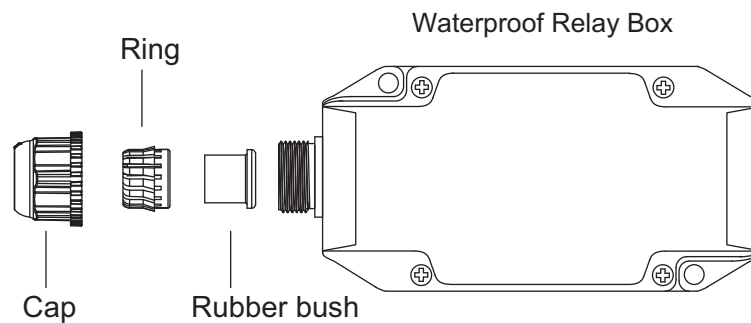

- 6) Fit the cover to the waterproof relay box, then secure the cover with the four washer screws removed at step 1.



2. WIRING

2.2.3 How to secure and waterproof the cable connections

Cable connection for the waterproof relay box, whether exposed to weather or otherwise, should be waterproofed and secured after making the connection.



- 1) Wrap the cap with several layers of self-bonding tape (supplied), to reduce the height difference between the cap and the box.



- 2) Starting at approximately 40 mm from the both caps, wrap the cap and waterproof relay box with three layers of self-bonding tape.

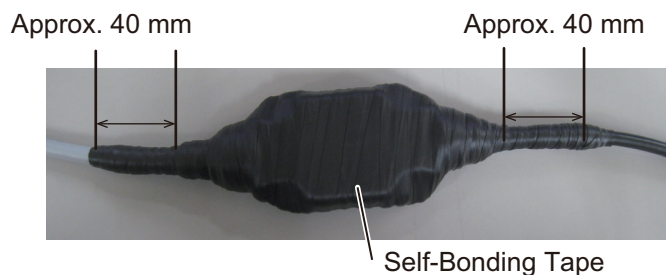

Note: Take care that the self-bonding tape is not cut on the waterproof relay box or cap edges.

- 3) Wrap two layers of vinyl tape, in opposite direction, to cover the self-bonding tape.



3. ADJUSTMENTS

When the unit is powered for the first time, it is in a “cold start” state. There is no satellite data (almanac data) stored. In this state, the unit searches for, and stores, satellites to find its heading. This process takes approximately 90 seconds. If the heading is not found within 30 minutes, the antenna installation location may not be suitable. A lack of visible satellites (less than four) can also prevent the unit from finding a heading. Resolve the problem, then re-check the tracking status.

If the heading error is between 5° and 10°, adjust the antenna unit orientation while monitoring the heading indication.

At installation, when the unit is powered for the first time, some of menus required initial setting. Initial settings can be done from the NMEA2000 network (TZTL2F/15F unit with software version V6.0 or later is required), or from a PC (using the SC Setting Tool). For how to use the PC tool, refer to the Operator’s Manual for PC tools (SC_Setting_Tool: OME-72851). Once a heading has been found, the following items may need setting or adjustment.

Also, when rebooting the SC-33, re-connecting of menu is required to operate from the TZTL12F/15F (V6. and after).

3.1 Initial Setting Menu

Offset

Adjust the offsets for heading, pitch, roll, air pressure and temperature as required.

Menu Item	Description	Setting Range
HDG	Offset the heading sensor. - Select the compensation value of the heading indication.	-180°.0 to +180°.0
Pitch	Offset to compensate for pitch. - Select the compensation value of the pitch.	-10°.0 to +10°.0
Roll	Offset to compensate for roll. - Select the compensation value of the roll.	-10°.0 to +10°.0
Air Pressure	Offset pressure. - Select the compensation value of the pressure.	-99.9 hPa to +99.9 hPa
Air Temperature	Offset temperature. - Check that the temperature inside the SC-33 is stable before applying any offsets to the temperature.	-99.9°C to +99.9°C

3. ADJUSTMENTS

Ship Size, ANT Position

Set the installation location, antenna position and ship size.

Menu Item	Description	Setting Range
Ship's Width	Set the ship's width.	1.0 m to 999.9 m
Ship's Length	Set the Ship's length.	1.0 m to 999.9 m
Ship's Height	Set the Ship's height.	1.0 m to 199.9 m
ANT Position X0	Port-starboard location of antenna unit. Enter a negative value for port-side, positive value for starboard-side. The center of the vessel is [0 m].	-327.64 m to +327.64 m
ANT Position Y0	Bow-stern location of the antenna unit. Calculated from the center of the bow.	0.0 m to 999.9 m
ANT Position Z0	Height of antenna unit location, from the bottom of the ship.	0.0 m to 199.9 m
CALC-SPD-POSN Y1 (Bow)	Ship's speed can be measured at two locations in addition to the antenna position. Normally, enter the bow position (Y1) and stern position (Y2).	0.0 m to 999.9 m
CALC-SPD-POSN Y2 (Stern)		0.0 m to 999.9 m
CALC-SPD-POSN Z (Height)	Enter the height from the bottom to calculate the ship's speed. To calculate the ship speed at the draught line, enter the height from the ship bottom to the draught.	0.0 m to 199.9 m

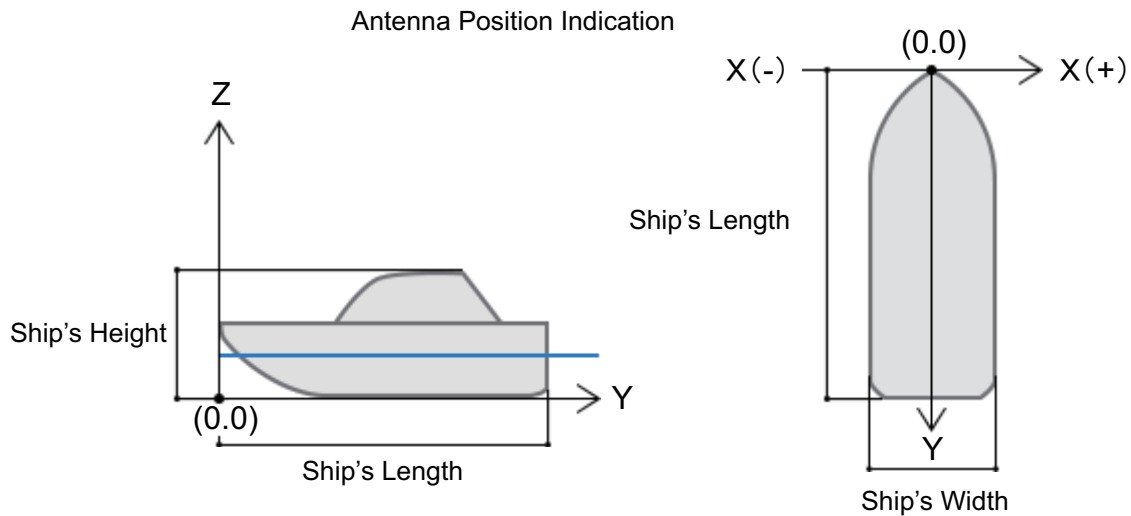

PGN

Setup the PGN data output. Select [0] to disable output, or select the required output cycle.

PGN	MENU ITEM	Output Cycle (ms)
065280	Heave	0 to 1000
126992	System Time	0 to 2000
126993	Heartbeat	0 to 60000
127250	Vessel Heading	0 to 6000
127251	Rate of Turn	0 to 1000
127252	Heave	0 to 1000
127257	Attitude	0 to 1000
127258	Magnetic Variation	0 to 1000
129025	Position, Rapid Update	0 to 1000
129026	COG and SOG, Rapid Update	0 to 1000
129029	GNSS Position Data	0 to 2000
129033	Time and Date	0 to 2000
129539	GNSS DOPs	0 to 2000
129540	GNSS Sats in View	0 to 2000
130310	Environmental Parameters	0 to 2000
130312	Temperature	0 to 2000
130314	Actual Pressure	0 to 2000
130316	Temperature, Extended Range	0 to 2000
130577	Direction Data	0 to 2000
130578	Vessel Speed Components	0 to 2000
130820	Motion Sensor Status	0 to 1000
130826	Multi Sats In View	0 to 2000
130842	Six Degrees of Freedom Movement	0 to 1000
130843	Heel Angle and Roll Information	0 to 1000
130845	Multi Sats In View Extended	0 to 2000
130846	Motion Sensor Status Extended	0 to 2000

3. ADJUSTMENTS

Simple Diagnostic Test

Run a diagnostic test.

Menu Item	Result	Setting Range
Start Diagnostic	Set to carry out the easy self-test	Start

The following table lists the items which are tested, along with a description and the possible test results.

Menu Item	Description	Result
ROM	ROM test result	OK, NG, -- (no set)
Internal RAM	Internal RAM test result	OK, NG, -- (no set)
GNSS1 ROM	GNSS1 ROM test result	OK, NG, -- (no set)
GNSS1 RAM	GNSS1 RAM test result	OK, NG, -- (no set)
GNSS2 ROM	GNSS2 ROM test result	OK, NG, -- (no set)
GNSS2 RAM	GNSS2 RAM test result	OK, NG, -- (no set)
GNSS3 ROM	GNSS3 ROM test result	OK, NG, -- (no set)
GNSS3 RAM	GNSS3 RAM test result	OK, NG, -- (no set)
CAN	CAN test result	OK, NG, -- (no set)
Main Accelerometer Status X	Accelerometer Status X (MAIN board) test result	OK, NG, -- (no set)
Main Accelerometer Status Y	Accelerometer Status Y (MAIN board) test result	OK, NG, -- (no set)
Main Accelerometer Status Z	Accelerometer Status Z (MAIN board) test result	OK, NG, -- (no set)
Main Rate Gyro Status X	Rate Gyro Status X (MAIN board) test result	OK, NG, -- (no set)
Main Rate Gyro Status Y	Rate Gyro Status Y (MAIN board) test result	OK, NG, -- (no set)
Main Rate Gyro Status Z	Rate Gyro Status Z (MAIN board) test result	OK, NG, -- (no set)
Main Magnetic Sensor Status	Magnetic Sensor Status (MAIN board) test result	OK, NG, -- (no set)
Main Pressure Sensor Status	Pressure Sensor Status (MAIN board) test result	OK, NG, -- (no set)
Sub IMU Accelerometer Status X	Accelerometer Status X (Sub IMU board) test result	OK, NG, -- (no set)
Sub IMU Accelerometer Status Y	Accelerometer Status Y (Sub IMU board) test result	OK, NG, -- (no set)
Sub IMU Accelerometer Status Z	Accelerometer Status Z (Sub IMU board) test result	OK, NG, -- (no set)
Sub IMU Rate Gyro Status X	Rate Gyro Status X (Sub IMU board) test result	OK, NG, -- (no set)
Sub IMU Rate Gyro Status Y	Rate Gyro Status Y (Sub IMU board) test result	OK, NG, -- (no set)
Sub IMU Rate Gyro Status Z	Rate Gyro Status Z (Sub IMU board) test result	OK, NG, -- (no set)

Menu Item	Description	Result
Sub IMU Magnetic Sensor Status	Magnetic Sensor Status (Sub IMU board) test result	OK, NG, -- (no set)
Sub IMU Pressure Sensor Status	Pressure Sensor Status (Sub IMU board) test result	OK, NG, -- (no set)
Antenna 1 Test	Antenna 1 test result	OK, NG, -- (no set)
Antenna 2 Test	Antenna 2 test result	OK, NG, -- (no set)

Reset Setting

You can clear the GNSS core settings, menu settings or restore the factory default settings.

Menu Item	Description	Select Item
GNSS	Clear the GNSS core settings	No, Yes
Menu Settings	Clear the User settings	No, Yes
Factory Reset	Restore the Factory settings	No, Yes

4. NMEA 2000 I/O DATA

The SC-33 handles the NMEA 2000 I/O data PGNs listed below. The LEN (Load Equivalency Number) is 11. (LEN is the amount of current a device draws from the NMEA 2000 network. 1 LEN = 50 mA.)

4.1 Input Data

PGN	Name	Remarks			
059392	ISO Acknowledgement				
059904	ISO Request	Request for PGN output of Note1 in the output data table on page 24.			
060160	ISO Transport Protocol, Data Transfer				
060416	ISO Transport Protocol, Connection Management - BAM Group Function	BAM = Broadband Announce Message			
060928	ISO Address Claim				
061184	Self Test Group Function				
065240	ISO Commanded Address				
126208	NMEA-Request Group Function	Request for PGN output of Note 1, 2 and 3 in the output data table on the page 24, also interval change for regular PGN output in the output data table on the next page.			
	NMEA-Command Group Function	Standard PGNs and their changeable fields			
		PGN	Name	Field	Name
		060928	ISO Address Claim	#3	Device Instance Lower
				#4	Device Instance Upper
				#8	System Instance
		126998	Configuration Information	#1	Installation Description, Field 1
				#2	Installation Description, Field 2
				#3	Installation Description, Field 3
		129538	GNSS Control Status	#1	SV Elevation Mask
#6	0 or 1 (Default 1) 0: SBAS OFF 1: SBAS ON				

PGN	Name	Remarks	
126208	NMEA-Command Group Function	Other setting change is possible other than the above used Furuno proprietary PGN.	
		PGN	Name
		126720	Variable Sensor Calibration Control Status
		130817	FURUNO GNSS Control Status
		130818	Heading & Attitude Sensor Control Status
		130819	Motion Sensor Control Status
		130833	Device Position and Ship Dimension Report
130834	Position of Speed Measurement		
126720	GMM Message	Proprietary PGN	

4.2 Output Data

PGN	Name	Remarks	
059392	ISO Acknowledgement	-	Output for rejection of output request by ISO Request.
060928	ISO Address Claim	Note 1, 2	- Transmission at the time of address generation. - Output for receiving the output request by ISO Request.
061184	Self Test Group Function	-	- Proprietary PGN - Output for receiving the Self Test Group Function
065280	Heave	100 ms	- Proprietary PGN
126208	NMEA-Acknowledge Group Function	-	
126464	PGN List - Transmit PGN's Group Function	Note 1, 2	
	PGN List - Received PGN's Group Function	Note 1, 2	
126720	GMM Message	-	- Proprietary PGN - Output for GMM Message received.
	Variable Sensor Calibration Control Status	Note 2	- Proprietary PGN
126992	System Time	1000 ms	
126993	Heart Beat	60000 ms	
126996	Product Information	Note 1, 2	
126998	Configuration Information	Note 1, 2	
127250	Vessel Heading	100 ms	
127251	Rate of Turn	100 ms	

4. NMEA 2000 I/O DATA

PGN	Name	Remarks	
127252	Heave	100 ms	
127257	Attitude	100 ms	
127258	Magnetic Variation	100 ms	
129025	Position, Rapid Update	100 ms	
129026	COG & SOG Rapid Update	250 ms	
129029	GNSS Position Data	1000 ms	
129033	Time & Date	Note 1, 2, 3	
129538	GNSS Control Status	Note 1, 2	
129539	GNSS DOPs	1000 ms	
129540	GNSS Sats in View	1000 ms	
129547	GNSS Pseudo Range Error Statistics	Note 1, 2	
130310	Environmental Parameters - DEPRECATED	500 ms	
130312	Temperature - DEPRECATED	2000 ms	
130314	Actual Pressure	2000 ms	
130316	Temperature, Extended Range	2000 ms	
130577	Direction Data	1000 ms	
130578	Vessel Speed Components	250 ms	
130816	Self Test Report	-	- Proprietary PGN - Output for Self Test Group Function received.
130817	Furuno GNSS Control Status	Note 2	- Proprietary PGN
130818	Heading & Attitude Sensor Control Status	Note 2	- Proprietary PGN
130819	Motion Sensor Control Status	Note 2	- Proprietary PGN
130820	Motion Sensor Status	1000 ms	- Proprietary PGN
130822	Unit Division Code	Note 2	- Proprietary PGN
130823	Blower Control Status	Note 2	- Proprietary PGN
130826	Multi Sats in View	1000 ms	- Proprietary PGN
130833	Device Position and Ship Dimension Report	Note 2	- Proprietary PGN
130834	Position of Speed Measurement	Note 2	- Proprietary PGN
130842	Six Degrees of Freedom Movement	Note 2	- Proprietary PGN
130843	Heel Angle & Roll Information	100 ms	- Proprietary PGN
130845	Multi Sats In View Extended	1000 ms	- Proprietary PGN
130846	Motion Sensor Status Extended	1000 ms	- Proprietary PGN
130847	System Debug Trace Data Stream	Note 2	- Proprietary PGN

Note 1: PGN to output independently when “PGN: 059904” or “PGN: 126028” requested.

Note 2: PGN to output independently when “PGN: 126028” requested.

Note 3: PGN to output regularly when “PGN: 126028” requested.

5. MAINTENANCE, TROUBLE-SHOOTING

This chapter provides the information for keeping your unit in good working order.

NOTICE

Do not apply paint, anti-corrosive sealant or contact spray to coating or plastic parts of the equipment.

Those items contain organic solvents that can damage coating and plastic parts, especially plastic connectors.

5.1 Preventive Maintenance

Regular maintenance is important for good performance. Following the procedures in the table below will help maintain performance.

Preventive maintenance

Item	Check point	Remedy
Connector	Check that connector is firmly fastened.	Reconnect cable if it has loosened.
Cabling	Visually check cabling for signs of wear and damage.	Replace damaged cables.
Cover	Cleanliness of cover	Dust can be removed with a soft cloth. Do not use chemical based cleaners to clean the cover, as they can remove paint and markings and deform the cover.

5.2 Troubleshooting

This section provides basic troubleshooting which the user may follow to restore normal operation. If the problem is not rectified, contact your dealer for advice.

Symptom	Possible cause and remedy
Heading is not output.	<p><u>Check installation site:</u></p> <ul style="list-style-type: none"> • Check for interfering objects near the antenna. • Check the installation site and mounting base for vibration. • Check for antenna of radar, radio equipment, etc. near the installation site. <p><u>Check connections:</u></p> <p>1) NMEA 2000 bus connection</p> <ul style="list-style-type: none"> • Check that the connector on the SC-33 is tightly connected. • Check that no stress is applied to the cable and that a loop has been made with the cable to prevent cable stress. • Check that terminators (120 ohm) are attached at each end of the NMEA 2000 network. • Check that the input voltage to the SC-33 is between 9 to 32 VDC. • Check that all devices connected to the NMEA 2000 bus are within the current capacity of the bus. • Check that the cable (FRU-NMEA-PMMF-060 (6m)) is used. (If power is fed through a trunk line, the feeder cable shall be no longer than 6 m). • If power to the SC-33 is fed directly from the ship's mains, check breaker switch on mains switchboard and fuse in power cable. <p>2) IF-NMEASC interface unit connection: See the IF-NMEASC's operator's manual.</p>
Heading output stops often. Position and GNSS-related items are output but heading is not	<ul style="list-style-type: none"> • Check for obstructions near the SC-33. • Check installation site for vibrations. • Check if other antennas (radar, radio, etc.) are near the installation site.
Equipment in NMEA 2000 network malfunctions when SC-33 is connected.	<ul style="list-style-type: none"> • Check that terminators (120 ohm) are attached at each end of the NMEA 2000 network. • Check that the input voltage to the SC-33 is between 9 to 32 VDC. • Check that all devices connected to the NMEA 2000 bus are within the current capacity of the bus. • Check that the cable (FRU-NMEA-PMMF-060 (6m)) is used. (If power is fed through a trunk line, the feeder cable shall be no longer than 6 m).
Heading is output normally in fine weather but is not output in bad weather.	<ul style="list-style-type: none"> • Check the installation site for vibrations.
Autopilot jerks suddenly.	<ul style="list-style-type: none"> • Check for obstructions near the SC-33. • Check the installation site and mounting base for vibrations. • Check if other antennas (radar, radio, etc.) are near the installation site. • Check operation at the autopilot: <ol style="list-style-type: none"> 1) Check that the rudder angle can be confirmed when heading output has stopped. Check that the necessary alarms are output. Confirm that the rudder returns to 0° and the set rudder angle is maintained. 2) Confirm that rudder does not jerk violently when heading output is resumed. For example, check that the setting for rudder angle limit is suitable.

APPENDIX 1 MENU TREE

For SC-33, the detailed setting of the sensor is available from the TZTL12F/15F (V6.0 and after) via the NMEA network.

Also, when rebooting SC-33, re-connecting of menu is required to operate from the TZTL12F/15F (V6.0 and after).

Refer to the OPERATOR'S MANUAL for each models.

MENU

Bold Italic: Default

[GNSS Setup]

Disable SV	QZSS All	(NO , YES)	
	QZSS 1	Set range (0 to 197; 0)	0: Disable the ignore function. 1 to 197 (excludes 1 to 182; and 188 to 192)
	QZSS 2	Set range (0 to 197; 0)	0: Disable the ignore function. 1 to 197 (excludes 1 to 182; and 188 to 192)
	QZSS 3	Set range (0 to 197; 0)	0: Disable the ignore function. 1 to 197 (excludes 1 to 182; and 188 to 192)
	GPS All	(NO , YES)	GPS1 to 3 is set to "0" at the setting.
	GPS 1	Set range (0 to 32; 0)	0: Disable the ignore function.
	GPS 2	Set range (0 to 32; 0)	0: Disable the ignore function.
	GPS 3	Set range (0 to 32; 0)	0: Disable the ignore function.
	GLONASS All	(NO , YES)	GLONASS1 to 3 is set to "0" at the setting.
	GLONASS	Set range (0 to 24; 0)	0: Disable the ignore function.
	GLONASS 2	Set range (0 to 24; 0)	0: Disable the ignore function.
	GLONASS 3	Set range (0 to 24; 0)	0: Disable the ignore function.
	Galileo All	(NO , YES)	GALILEO 01 to 3 is set to "0" at the setting.
	Galileo 1	Set range (0 to 36; 0)	0: Disable the ignore function.
	Galileo 2	Set range (0 to 36; 0)	0: Disable the ignore function.
	Galileo 3	Set range (0 to 36; 0)	0: Disable the ignore function.
SV ELEV	SV ELEV	Set range (5 to 90; 5)	
QZSS	ON/OFF		

*1 : Setting is required at installation.
(For technician)

[Sensor]

Offset ^{*1}	HDG	Set range (-180.0 to 180; 0.0)
	Pitch	Set range (-10.0 to 10.0; 0.0)
	Roll	Set range (-10.0 to 10.0; 0.0)
	Air Pressure	Set range (-99.9 to 99.9; 0.0)
	Air Temperature	Set range (-99.9 to 99.9; 0.0)
DR Time	DR Time	Set range (1 to 5; 5)
Ship Size, ANT Position ^{*1}	Ship's Width	Set range (1.0 to 999.9; 6.0)
	Ship's Length	Set range (1.0 to 999.9; 20.0)
	Ship's Height	Set range (1.0 to 199.9; 8.0)
	ANT Position X0	Set range (-327.64 to 327.64; 0.00)
	ANT Position Y0	Set range (0.0 to 999.9; 10.0)
	ANT Position Z0	Set range (0.0 to 199.9; 6.0)
	CALC-SPD-POSN Y1 (Bow)	Set range (0.0 to 999.9; 0.0)
CALC-SPD-POSN Y2 (Stern)	Set range (0.0 to 999.9; 20.0)	
	CALC-SPD-POSN Z (Height)	Set range (0.0 to 199.9; 0.0)

①

Bold Italic: Default

①

[Input / Output]

PGN ^{*1}	PGN: 065280 (Heave)	Set range (0 to 1000; <i>100</i>)	0: Disable output
	PGN: 126992 (System Time)	Set range (0 to 2000; <i>1000</i>)	0: Disable output
	PGN: 126993 (Heartbeat)	Set range (0 to 60000; <i>60000</i>)	0: Disable output
	PGN: 127250 (Vessel Heading)	Set range (0 to 1000; <i>100</i>)	0: Disable output
	PGN: 127251 (Rate of Turn)	Set range (0 to 1000; <i>100</i>)	0: Disable output
	PGN: 127252 (Heave)	Set range (0 to 1000; <i>100</i>)	0: Disable output
	PGN: 127257 (Attitude)	Set range (0 to 1000; <i>100</i>)	0: Disable output
	PGN: 127258 (Magnetic Variation)	Set range (0 to 1000; <i>100</i>)	0: Disable output
	PGN: 129025 (Position, Rapid Update)	Set range (0 to 1000; <i>100</i>)	0: Disable output
	PGN: 129026 (COG and SOG, Rapid Update)	Set range (0 to 2000; <i>250</i>)	0: Disable output
	PGN: 129029 (GNSS Position Data)	Set range (0 to 2000; <i>1000</i>)	0: Disable output
	PGN: 129033 (Time and Date)	Set range (0 to 2000; <i>0</i>)	0: Disable output
	PGN: 129539 (GNSS DOPs)	Set range (0 to 2000; <i>1000</i>)	0: Disable output
	PGN: 129540 (GNSS Sats in View)	Set range (0 to 2000; <i>1000</i>)	0: Disable output
	PGN: 130310 (Environmental Parameters)	Set range (0 to 2000; <i>500</i>)	0: Disable output
	PGN: 130312 (Temperature)	Set range (0 to 2000; <i>2000</i>)	0: Disable output
	PGN: 130314 (Actual Pressure)	Set range (0 to 2000; <i>2000</i>)	0: Disable output
	PGN: 130316 (Temperature, Extended Range)	Set range (0 to 2000; <i>2000</i>)	0: Disable output
	PGN: 130577 (Direction Data)	Set range (0 to 2000; <i>1000</i>)	0: Disable output
	PGN: 130578 (Vessel Speed Components)	Set range (0 to 2000; <i>250</i>)	0: Disable output
	PGN: 130820 (Motion Sensor Status)	Set range (0, 1000; <i>1000</i>)	0: Disable output
	PGN: 130826 (Multi Sats In View)	Set range (0 to 2000; <i>1000</i>)	0: Disable output
	PGN: 130842 (Six Degrees of Freedom Movement)	Set range (0 to 1000; <i>0</i>)	0: Disable output
	PGN: 130843 (Heel Angle and Roll Information)	Set range (0 to 1000; <i>100</i>)	0: Disable output
	PGN: 130845 (Multi Sats In View Extended)	Set range (0 to 2000; <i>1000</i>)	0: Disable output
	PGN: 130846 (Motion Sensor Status Extended)	Set range (0 to 2000; <i>1000</i>)	0: Disable output

②

*1 : Setting is required at installation.
(For technician)

②

[System]

Bold Italic: Default

System Information	<ul style="list-style-type: none"> Main PCB Sub IMU PCB * Fixed "--" when the SUB_IMU board is not installed. MAIN CPU OS Version MAIN CPU Application Version WMM GNSS1 * Displays "--" when the version is invalid. GNSS2 * Displays "--" when the version is invalid. GNSS3 * Displays "--" when the version is invalid. CAN Unique Number Main Overall Powered Time Sub IMU Runtime * Fixed "--" when the SUB_IMU board is not installed. Antenna1 Powered Time Antenna2 Powered Time Model 	
Simple Diagnostic Test	<ul style="list-style-type: none"> Start Diagnostic Set range (START) ROM (OK, NG, -- (Not set)) Internal RAM (OK, NG, -- (Not set)) GNSS1 ROM (OK, NG, -- (Not set)) GNSS1 RAM (OK, NG, -- (Not set)) GNSS2 ROM (OK, NG, -- (Not set)) GNSS2 RAM (OK, NG, -- (Not set)) GNSS3 ROM (OK, NG, -- (Not set)) GNSS3 RAM (OK, NG, -- (Not set)) CAN (OK, NG, -- (Not set)) Main Accelerometer Status X (OK, NG, -- (Not set)) Main Accelerometer Status Y (OK, NG, -- (Not set)) Main Accelerometer Status Z (OK, NG, -- (Not set)) Main Rate Gyro Status X (OK, NG, -- (Not set)) Main Rate Gyro Status Y (OK, NG, -- (Not set)) Main Rate Gyro Status Z (OK, NG, -- (Not set)) Main Magnetic Sensor Status (OK, NG, -- (Not set)) Main Pressure Sensor Status (OK, NG, -- (Not set)) Sub IMU Accelerometer Status X (OK, NG, -- (Not set)) Sub IMU Accelerometer Status Y (OK, NG, -- (Not set)) Sub IMU Accelerometer Status Z (OK, NG, -- (Not set)) Sub IMU Rate Gyro Status X (OK, NG, -- (Not set)) Sub IMU Rate Gyro Status Y (OK, NG, -- (Not set)) Sub IMU Rate Gyro Status Z (OK, NG, -- (Not set)) Sub IMU Magnetic Sensor Status (OK, NG, -- (Not set)) Sub IMU Pressure Sensor Status (OK, NG, -- (Not set)) Antenna1 Test (OK, NG, -- (Not set)) Antenna2 Test (OK, NG, -- (Not set)) 	
Reset Setting	<ul style="list-style-type: none"> GNSS (<i>NO</i>, YES) Menu Settings (<i>NO</i>, YES) Factory Reset (<i>NO</i>, YES) 	*1 : Setting is required at installation. (For technician)
Performance	<ul style="list-style-type: none"> CPU Memory 	*2 : (For developer)
Offline ^{*2}	<ul style="list-style-type: none"> Offline (<i>OFF</i>, ON) 	

③

③

[Advanced Sensor Setting]

Bold Italic: Default

Rate Gyro	Main X Percent	Indication range	(-8.0 to 8.0; <i>0.0</i>)
	Main Y Percent	Indication range	(-8.0 to 8.0; <i>0.0</i>)
	Main Z Percent	Indication range	(-8.0 to 8.0; <i>0.0</i>)
	Main X Offset	Indication range	(-1999 to 1999; <i>0</i>)
	Main Y Offset	Indication range	(-1999 to 1999; <i>0</i>)
	Main Z Offset	Indication range	(-1999 to 1999; <i>0</i>)
	Sub IMU X Percent	Set range	(-8.0 to 8.0; <i>0.0</i>)
	Sub IMU Y Percent	Set range	(-8.0 to 8.0; <i>0.0</i>)
	Sub IMU Z Percent	Set range	(-8.0 to 8.0; <i>0.0</i>)
	Sub IMU X Offset	Set range	(-1999 to 1999; <i>0</i>)
	Sub IMU Y Offset	Set range	(-1999 to 1999; <i>0</i>)
	Sub IMU Z Offset	Set range	(-1999 to 1999; <i>0</i>)
	Accelerometer	Main X Percent	Indication range
Main Y Percent		Indication range	(-9.9 to 9.9; <i>0.0</i>)
Main Z Percent		Indication range	(-9.9 to 9.9; <i>0.0</i>)
Main X Offset		Indication range	(-1999 to 1999; <i>0</i>)
Main Y Offset		Indication range	(-1999 to 1999; <i>0</i>)
Main Z Offset		Indication range	(-1999 to 1999; <i>0</i>)
Sub IMU X Percent		Set range	(-9.9 to 9.9; <i>0.0</i>)
Sub IMU Y Percent		Set range	(-9.9 to 9.9; <i>0.0</i>)
Sub IMU Z Percent		Set range	(-9.9 to 9.9; <i>0.0</i>)
Sub IMU X Offset		Set range	(-1999 to 1999; <i>0</i>)
Sub IMU Y Offset		Set range	(-1999 to 1999; <i>0</i>)
Sub IMU Z Offset		Set range	(-1999 to 1999; <i>0</i>)
Magnetic		Main X Percent	Indication range
	Main Y Percent	Indication range	(-29.0 to 29.0; <i>1.0</i>)
	Main Z Percent	Indication range	(-29.0 to 29.0; <i>0.0</i>)
	Main X Offset	Indication range	(-1999 to 1999; <i>0</i>)
	Main Y Offset	Indication range	(-1999 to 1999; <i>0</i>)
	Main Z Offset	Indication range	(-1999 to 1999; <i>0</i>)
	Sub IMU X Percent	Set range	(-29.0 to 29.0; <i>1.0</i>)
	Sub IMU Y Percent	Set range	(-29.0 to 29.0; <i>1.0</i>)
	Sub IMU Z Percent	Set range	(-29.0 to 29.0; <i>0.0</i>)
	Sub IMU X Offset	Set range	(-1999 to 1999; <i>0</i>)
	Sub IMU Y Offset	Set range	(-1999 to 1999; <i>0</i>)
	Sub IMU Z Offset	Set range	(-1999 to 1999; <i>0</i>)
	Air Pressure	Main Offset	Indication range
Sub IMU Offset		Set range	(-99.9 to 99.9; <i>0.0</i>)
Air Temperature	Main Offset	Indication range	(-99.9 to 99.9; <i>-12.0</i>)
	Sub IMU Offset	Set range	(-99.9 to 99.9; <i>-12.0</i>)

APPENDIX 2 WHAT IS SBAS?

A satellite based augmentation system, or SBAS (Satellite Based Augmentation System), is an augmentation system that uses additional messages from satellite broadcasts to support regional and wide area augmentation. SBAS provides GPS signal corrections to SBAS users, for even better position accuracy, through the GPS error corrections that are widely broadcasted from the geostationary satellite.

SBAS is used in America, Europe, Japan and India.

- America: WAAS (Wide Area Augmentation System)
- Europe: EGNOS (Euro Geostationary Navigation Overlay Service)
- Japan: MSAS (Multi-Functional Satellite Augmentation System)
- India: GAGAN (GPS And GEO Augmented Navigation)

These four systems have interoperability. The illustration below shows the coverage area for each provider. This manual uses "SBAS" for these four providers generically.

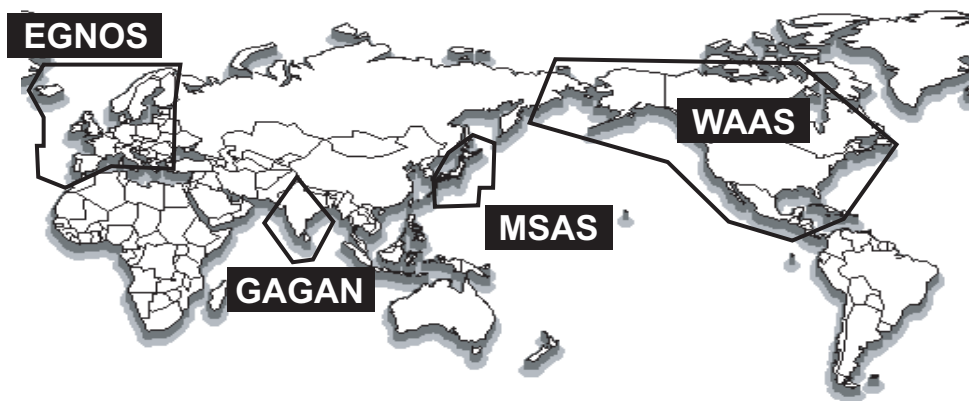

Provider	Satellite type	Longitude	Satellite No.
WAAS	Intelsat Galaxy XV	133°W	135
	TeleSat Anik F1R	107.3°W	138
	Inmarsat-4-F3	98°W	133
EGNOS	Inmarsat-3-F2/AOR-E	15.5°W	120
	Artemis	21.5°E	124
	Inmarsat-4-F2	25°E	126
	SES-5	5°E	136
MSAS	MTSAT-1R	140°E	129
	MTSAT-2	145°E	137
GAGAN	GSAT-8	55°E	127
	GSAT-10	83°E	128

As of March 6th, 2014

**SPECIFICATIONS OF SATELLITE COMPASS
SC-33**

1 GENERAL

- 1.1 Frequency L1 1575.42MHz (GPS/Galileo/QZSS), 1602.5625MHz (GLONASS)
- 1.2 Tracking code C/A (GPS/QZSS), E1B (Galileo), 10F (GLONASS)
- 1.3 Attitude accuracy Heading/ Roll/ Pitch: 0.4° rms
- 1.4 Follow-up 45°/sec
- 1.5 Heave accuracy 30 cm
- 1.6 Attitude setting time 90 s approx.
- 1.7 Position accuracy (dependent on ionospheric activity and multipath)
 - GNSS 5 m approx. (2drms, HDOP<4)
 - SBAS 4 m approx. (2drms, HDOP<4)
 - WAAS 3 m approx. (2drms, HDOP<4)
- 1.8 Position fixing time 60 s approx.
- 1.9 Update interval Attitude: 50 Hz max, Position: 10 Hz max.
- 1.10 Ship's speed accuracy
 - Number of satellite ≥ 5: 0.2% of ship's speed or 0.02 kn rms, whichever is greater
 - Number of satellite 3 to 4: 1% of ship's speed or 0.1 kn rms, whichever is greater
- 1.11 Pressure sensor
 - Measuring range 850 to 1100 hPa (ambient temperature: 0 to +50°C)
 - Accuracy ±1.0 hPa (adjusted value after offset regulation)
- 1.12 Temperature sensor
 - Measuring range -20°C to +55°C (relative speed 4 kn or more)
 - Accuracy ±2.0°C (adjusted value after offset regulation)
- 1.13 Interface port NMEA2000: 1 port
 - Input PGN 059392/904, 060160/416/928, 061184, 065240, 126208
 - Output PGN 059392, 060928, 061184, 065280,
126208/464/992/993/996/998, 127250/251/252/257/258,
129025/026/029/033/538/539/540/547,
130310/312/314/316/577/578/816/817/818/819/820/822/823/826,
130833/834/842/843/845/846/847

2 POWER SUPPLY

12-24 VDC: 0.4-0.2 A (LEN: 11)

3 ENVIRONMENTAL CONDITIONS

- 3.1 Ambient temperature -25°C to +55°C (storage: -30°C to +70°C)
- 3.2 Relative humidity 95% or less at +40°C
- 3.3 Degree of protection IP56
- 3.4 Vibration IEC 60945 Ed.4

4 UNIT COLOR

N9.5

PACKING LIST

20BJ-X-9851 -1 1/1

SC-33-J-0, SC-33E-0

A-1

NAME	OUTLINE	DESCRIPTION/CODE No.	QTY
ユニット			
センサー		SC-33	1
SENSOR		000-0335-093-00	
工事材料			
INSTALLATION MATERIALS			
工事材料		CP20-04401	1
INSTALLATION MATERIALS		001-508-130-00	
図書			
DOCUMENT			
取扱説明書		0M*-72850-*	1
OPERATOR'S MANUAL		000-194-661-1**	

コード番号末尾の[**]は、運送品の代表コードを表します。
CODE NUMBER ENDING WITH "**" INDICATES THE CODE NUMBER OF REPRESENTATIVE MATERIAL.

(略図の寸法は、参考値です。 DIMENSIONS IN DRAWING FOR REFERENCE ONLY.)

C7285-Z01-B

PACKING LIST

20BJ-X-9852 -2 1/1

SC-33-J-6, SC-33-E-6

A-2

NAME	OUTLINE	DESCRIPTION/CODE No.	QTY
ユニット			
センサー		SC-33	1
SENSOR		000-0335-093-00	
工事材料			
INSTALLATION MATERIALS			
ケーブル(のび)NMEA		FRU-NMEA-PMWFF-060	1
CABLE ASSEMBLY		000-194-602-10	
工事材料		CP20-04401	1
INSTALLATION MATERIALS		001-508-130-00	
図書			
DOCUMENT			
取扱説明書		0M*-72850-*	1
OPERATOR'S MANUAL		000-194-661-1**	

コード番号末尾の[**]は、運送品の代表コードを表します。
CODE NUMBER ENDING WITH "**" INDICATES THE CODE NUMBER OF REPRESENTATIVE MATERIAL.

(略図の寸法は、参考値です。 DIMENSIONS IN DRAWING FOR REFERENCE ONLY.)

C7285-Z02-C

PACKING LIST

20BJ-X-9853 -2 1/1

SC-33-J-15

A-3

NAME	UNIT	OUTLINE	DESCRIPTION/CODE No.	QTY
ユニット				
センサー			SC-33	1
SENSOR			000-0335-093-00	
工事材料				
INSTALLATION MATERIALS				
ケーブル(クモシカ)NMEA			FRU-NMEA-NFF-R15	1
CABLE ASSEMBLY			000-194-637-10	
工事材料			CP20-04401	1
INSTALLATION MATERIALS			001-508-130-00	
図書				
DOCUMENT				
取扱説明書			OMJ-72850-*	1
OPERATOR'S MANUAL			000-194-660-1*	

(略図の寸法は、参考値です。 DIMENSIONS IN DRAWING FOR REFERENCE ONLY.)

C7285-Z03-C

PACKING LIST

20BJ-X-9854 -0 1/1

OP20-50

A-4

NAME	KIT PARTS	OUTLINE	DESCRIPTION/CODE No.	QTY
キット内容				
ケーブル(クモシカ)NMEA			FRU-NMEA-PFF-060	1
CABLE ASSEMBLY			000-194-606-10	
抵抗器(組品)			120-0HM-1007#24-L50	1
RESISTOR ASSEMBLY			000-167-746-11	
ビニールテープ			0.2X19X10000MM 70	1
VINYL TAPE			000-172-691-10	
自己接着テープ			NO. 15	1
SELF-BONDING TAPE			000-174-646-10	
防水中継ボックス			JPBS 06	1
WATERPROOF RELAY BOX			000-194-639-10	





(略図の寸法は、参考値です。 DIMENSIONS IN DRAWING FOR REFERENCE ONLY.)

C7285-Z04-A

FURUNO

CODE NO.	001-508-130-00	208J-X-9401-0
TYPE	CP20-04401	1/1

工事材料表

INSTALLATION MATERIALS		略 図 OUTLINE	型名/規格 DESCRIPTIONS	数 量 Q T Y	用途/備考 REMARKS
番 号 NO.	名 称 NAME				
1	六角ナット 1/2 HEX NUT		M10 SUS304 CODE NO. 000-166-475-10	8	
2	ハネばね金 SPRING WASHER		M10 SUS304 CODE NO. 000-167-233-10	4	
3	平ばね金 FLAT WASHER		M10 SUS316L CODE NO. 000-167-416-10	4	
4	接着剤塗布 ADHESIVE		TB5211 50G CODE NO. 001-477-870-00	1	

(略図の寸法は、参考値です。 DIMENSIONS IN DRAWING FOR REFERENCE ONLY.)

FURUNO ELECTRIC CO., LTD.

C7285-M01-A



表1 TABLE 1

寸法区分 (mm) DIMENSION	公差 (mm) TOLERANCE
$L \leq 50$	± 1.5
$50 < L \leq 100$	± 2.5
$100 < L \leq 500$	± 3
$500 < L \leq 1000$	± 4

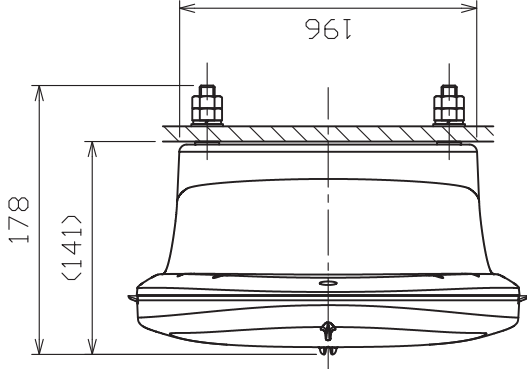
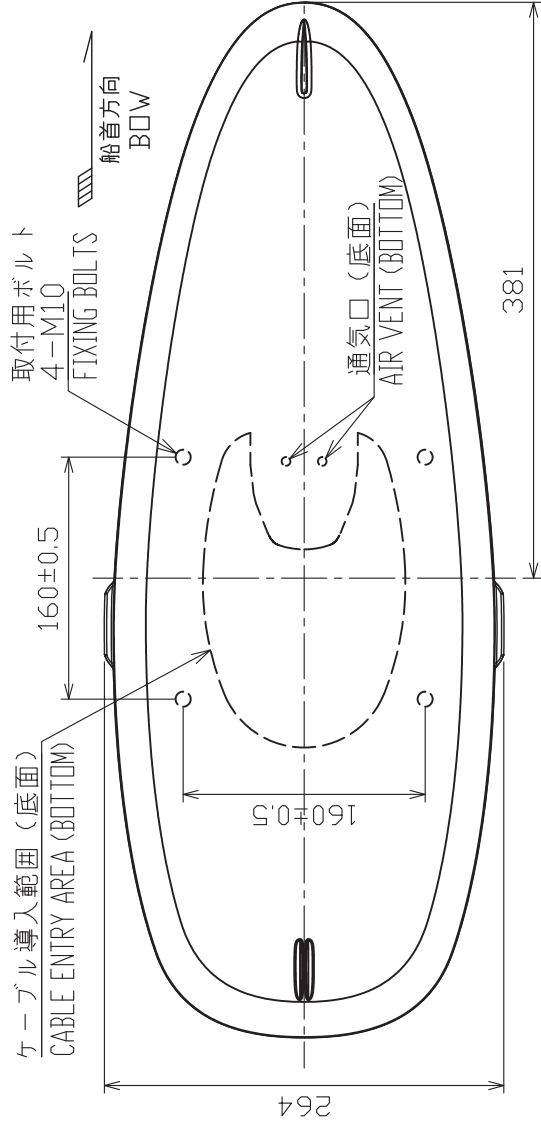
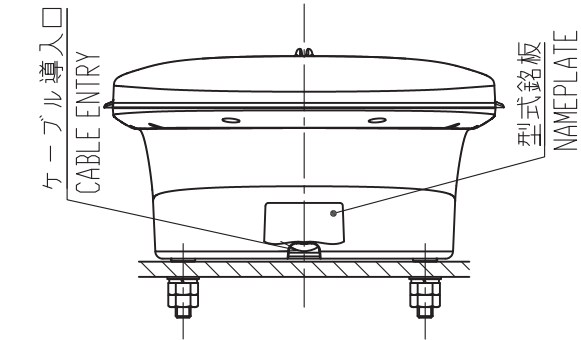
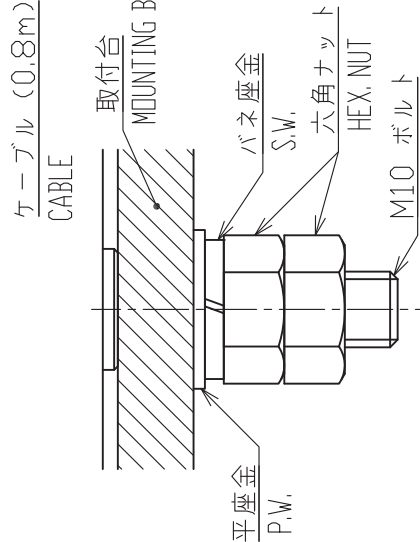

注記 1) 指定外の寸法公差は表1による。
2) 取付台の厚さ (t) は、5以上15以下とする。

NOTE 1. TABLE 1 INDICATES TOLERANCE OF DIMENSIONS WHICH IS NOT SPECIFIED.
2. MOUNTING BASE THICKNESS (t): $5 \leq t \leq 15$.

DRAWN	24/Jan/18	I.YAMASAKI	TITLE	SC-33
CHECKED	24/Jan/18	H.MAKI	名称	サテライトコンパス
APPROVED	24/Jan/2018	H.MAKI	外寸図	
SCALE	1/5	MASS 2.8 kg	標準は工程を含み MASS DOES NOT INCLUDE INST. MATERIALS.	SATELLITE COMPASS
FIG.No.	C7285-501-B	REF.No.	20-041-300G-1	OUTLINE DRAWING

A部 詳細 (尺度: 1/1)
DETAIL FOR A (SCALE: 1/1)

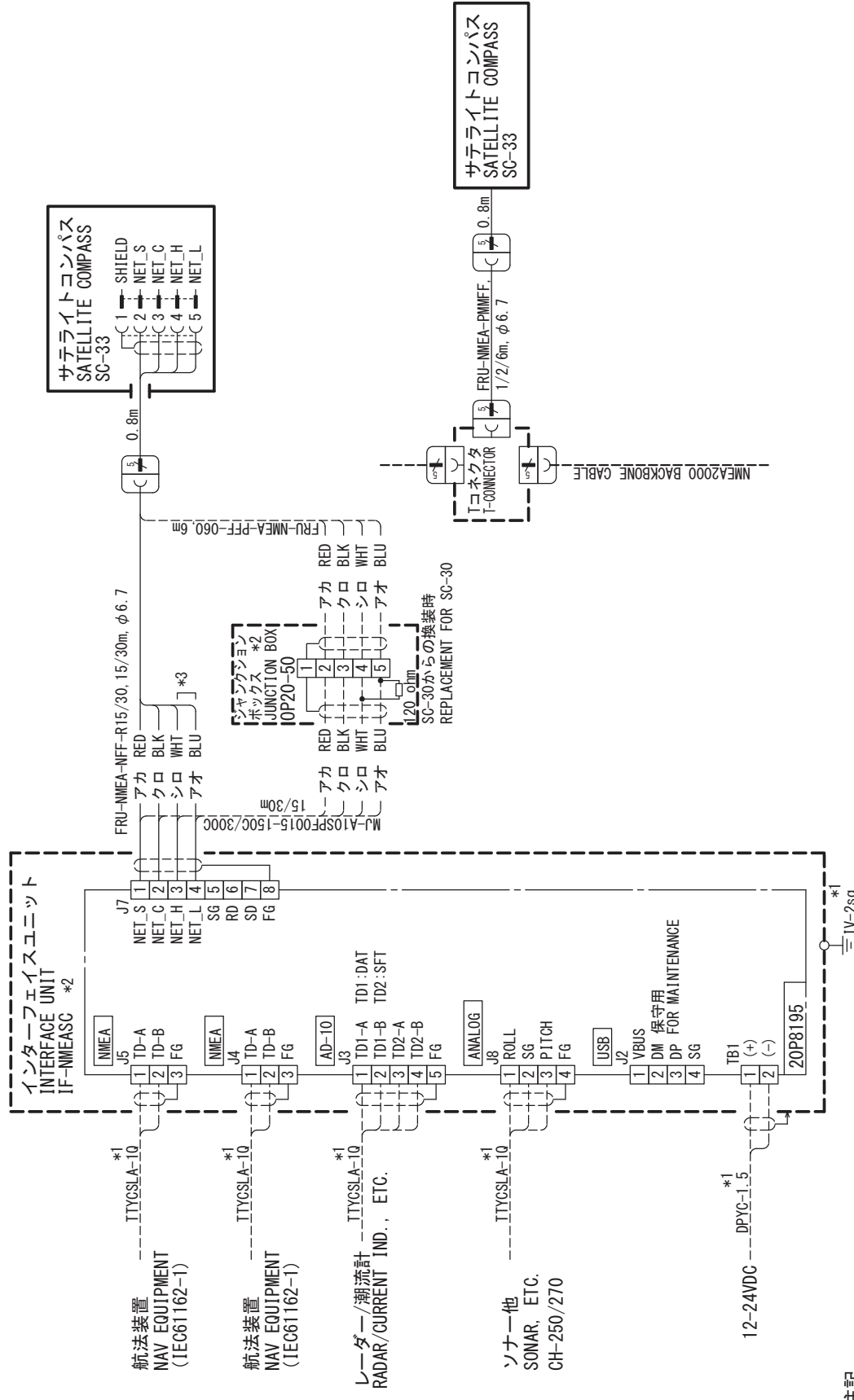

注記
 * 1) 造船所手配。
 * 2) オプション。
 * 3) 終端抵抗内蔵。

NOTE
 *1: SHIPYARD SUPPLY.
 *2: OPTION.
 *3: TERMINATOR INSERTED.

DRAWN	24/Oct/2017	T. YAMASAKI	TITLE	SC-33
CHECKED	24/Oct/2017	H. MAKI	名称	サテライトコンパス
APPROVED	26/Oct/2017	H. MAKI	相互結線図	
SCALE	MASS	kg	NAME	SATELLITE COMPASS
DWG. No.	C7285-C01-A	REF. No.	20-041-5001-0	INTERCONNECTION DIAGRAM

FURUNO Worldwide Warranty for Pleasure Boats (Except North America)

This warranty is valid for products manufactured by Furuno Electric Co. (hereafter FURUNO) and installed on a pleasure boat. Any web based purchases that are imported into other countries by anyone other than a FURUNO certified dealer may not comply with local standards. FURUNO strongly recommends against importing these products from international websites as the imported product may not work correctly and may interfere with other electronic devices. The imported product may also be in breach of the local laws and mandated technical requirements. Products imported into other countries as described previously shall not be eligible for local warranty service.

For products purchased outside of your country please contact the national distributor of Furuno products in the country where purchased.

This warranty is in addition to the customer's statutory legal rights.

1. Terms and Conditions of Warranty

FURUNO guarantees that each new FURUNO product is the result of quality materials and workmanship. The warranty is valid for a period of 2 years (24 months) from the date of the invoice, or the date of commissioning of the product by the installing certified dealer.

2. FURUNO Standard Warranty

The FURUNO standard warranty covers spare parts and labour costs associated with a warranty claim, provided that the product is returned to a FURUNO national distributor by prepaid carrier.

The FURUNO standard warranty includes:

- Repair at a FURUNO national distributor
- All spare parts for the repair
- Cost for economical shipment to customer

3. FURUNO Onboard Warranty

If the product was installed/commissioned and registered by a certified FURUNO dealer, the customer has the right to the onboard warranty.

The FURUNO onboard warranty includes

- Free shipping of the necessary parts
- Labour: Normal working hours only
- Travel time: Up to a maximum of two (2) hours
- Travel distance: Up to a maximum of one hundred and sixty (160) KM by car for the complete journey

4. Warranty Registration

For the Standard Warranty - presentation of product with serial number (8 digits serial number, 1234-5678) is sufficient. Otherwise, the invoice with serial number, name and stamp of the dealer and date of purchase is shown.

For the Onboard Warranty your FURUNO certified dealer will take care of all registrations.

5. Warranty Claims

For the Standard Warranty - simply send the defective product together with the invoice to a FURUNO national distributor. For the Onboard Warranty – contact a FURUNO national distributor or a certified dealer. Give the product's serial number and describe the problem as accurately as possible.

Warranty repairs carried out by companies/persons other than a FURUNO national distributor or a certified dealer is not covered by this warranty.

6. Warranty Limitations

When a claim is made, FURUNO has a right to choose whether to repair the product or replace it.

The FURUNO warranty is only valid if the product was correctly installed and used. Therefore, it is necessary for the customer to comply with the instructions in the handbook. Problems which result from not complying with the instruction manual are not covered by the warranty.

FURUNO is not liable for any damage caused to the vessel by using a FURUNO product.

The following are excluded from this warranty:

- a. Second-hand product
- b. Underwater unit such as transducer and hull unit
- c. Routine maintenance, alignment and calibration services.
- d. Replacement of consumable parts such as fuses, lamps, recording papers, drive belts, cables, protective covers and batteries.
- e. Magnetron and MIC with more than 1000 transmitting hours or older than 12 months, whichever comes first.
- f. Costs associated with the replacement of a transducer (e.g. Crane, docking or diver etc.).
- g. Sea trial, test and evaluation or other demonstrations.
- h. Products repaired or altered by anyone other than the FURUNO national distributor or an authorized dealer.
- i. Products on which the serial number is altered, defaced or removed.
- j. Problems resulting from an accident, negligence, misuse, improper installation, vandalism or water penetration.
- k. Damage resulting from a force majeure or other natural catastrophe or calamity.
- l. Damage from shipping or transit.
- m. Software updates, except when deemed necessary and warrantable by FURUNO.
- n. Overtime, extra labour outside of normal hours such as weekend/holiday, and travel costs above the 160 KM allowance
- o. Operator familiarization and orientation.

FURUNO Electric Company, March 1, 2011

FURUNO Warranty for North America

FURUNO U.S.A., Limited Warranty provides a twenty-four (24) months LABOR and twenty-four (24) months PARTS warranty on products from the date of installation or purchase by the original owner. Products or components that are represented as being waterproof are guaranteed to be waterproof only for, and within the limits, of the warranty period stated above. The warranty start date may not exceed eighteen (18) months from the original date of purchase by dealer from Furuno USA and applies to new equipment installed and operated in accordance with Furuno USA's published instructions.

Magnetrons and Microwave devices will be warranted for a period of 12 months from date of original equipment installation.

Furuno U.S.A., Inc. warrants each new product to be of sound material and workmanship and through its authorized dealer will exchange any parts proven to be defective in material or workmanship under normal use at no charge for a period of 24 months from the date of installation or purchase.

Furuno U.S.A., Inc., through an authorized Furuno dealer will provide labor at no cost to replace defective parts, exclusive of routine maintenance or normal adjustments, for a period of 24 months from installation date provided the work is done by Furuno U.S.A., Inc. or an AUTHORIZED Furuno dealer during normal shop hours and within a radius of 50 miles of the shop location.

A suitable proof of purchase showing date of purchase, or installation certification must be available to Furuno U.S.A., Inc., or its authorized dealer at the time of request for warranty service.

This warranty is valid for installation of products manufactured by Furuno Electric Co. (hereafter FURUNO). Any purchases from brick and mortar or web-based resellers that are imported into other countries by anyone other than a FURUNO certified dealer, agent or subsidiary may not comply with local standards. FURUNO strongly recommends against importing these products from international websites or other resellers, as the imported product may not work correctly and may interfere with other electronic devices. The imported product may also be in breach of the local laws and mandated technical requirements. Products imported into other countries, as described previously, shall not be eligible for local warranty service.

For products purchased outside of your country please contact the national distributor of Furuno products in the country where purchased.

WARRANTY REGISTRATION AND INFORMATION

To register your product for warranty, as well as see the complete warranty guidelines and limitations, please visit www.furunousa.com and click on "Support". In order to expedite repairs, warranty service on Furuno equipment is provided through its authorized dealer network. If this is not possible or practical, please contact Furuno U.S.A., Inc. to arrange warranty service.

FURUNO U.S.A., INC.
Attention: Service Coordinator
4400 N.W. Pacific Rim Boulevard
Camas, WA 98607-9408
Telephone: (360) 834-9300
FAX: (360) 834-9400

Furuno U.S.A., Inc. is proud to supply you with the highest quality in Marine Electronics. We know you had several choices when making your selection of equipment, and from everyone at Furuno we thank you. Furuno takes great pride in customer service.

Declaration of Conformity

[SC-33]

- Bulgarian (BG)** С настоящото Furuno Electric Co., Ltd. декларира, че гореспоменат тип радиосъоръжение е в съответствие с Директива 2014/53/ЕС.
Цялостният текст на ЕС декларацията за съответствие може да се намери на следния интернет адрес:
- Spanish (ES)** Por la presente, Furuno Electric Co., Ltd. declara que el tipo de equipo radioeléctrico arriba mencionado es conforme con la Directiva 2014/53/UE.
El texto completo de la declaración UE de conformidad está disponible en la dirección Internet siguiente:
- Czech (CS)** Tímto Furuno Electric Co., Ltd. prohlašuje, že výše zmíněné typ rádiového zařízení je v souladu se směrnicí 2014/53/EU.
Úplné znění EU prohlášení o shodě je k dispozici na této internetové adrese:
- Danish (DA)** Hermed erklærer Furuno Electric Co., Ltd., at ovennævnte radioudstyr er i overensstemmelse med direktiv 2014/53/EU.
EU-overensstemmelseserklæringens fulde tekst kan findes på følgende internetadresse:
- German (DE)** Hiermit erkläre die Furuno Electric Co., Ltd., dass der oben genannte Funkanlagentyp der Richtlinie 2014/53/EU entspricht.
Der vollständige Text der EU-Konformitätserklärung ist unter der folgenden Internetadresse verfügbar:
- Estonian (ET)** Käesolevaga deklareerib Furuno Electric Co., Ltd., et ülalmainitud raadioseadme tüüp vastab direktiivi 2014/53/EL nõuetele.
ELi vastavusdeklaratsiooni täielik tekst on kättesaadav järgmisel internetiaadressil:
- Greek (EL)** Με την παρούσα η Furuno Electric Co., Ltd., δηλώνει ότι ο προαναφερθέντας ραδιοεξοπλισμός πληροί την οδηγία 2014/53/ΕΕ.
Το πλήρες κείμενο της δήλωσης συμμόρφωσης ΕΕ διατίθεται στην ακόλουθη ιστοσελίδα στο διαδίκτυο:
- English (EN)** Hereby, Furuno Electric Co., Ltd. declares that the above-mentioned radio equipment type is in compliance with Directive 2014/53/EU.
The full text of the EU declaration of conformity is available at the following internet address:
- French (FR)** Le soussigné, Furuno Electric Co., Ltd., déclare que l'équipement radioélectrique du type mentionné ci-dessus est conforme à la directive 2014/53/UE.
Le texte complet de la déclaration UE de conformité est disponible à l'adresse internet suivante:
- Croatian (HR)** Furuno Electric Co., Ltd. ovime izjavljuje da je gore rečeno radijska oprema tipa u skladu s Direktivom 2014/53/EU.
Cjeloviti tekst EU izjave o sukladnosti dostupan je na sljedećoj internetskoj adresi:
- Italian (IT)** Il fabbricante, Furuno Electric Co., Ltd., dichiara che il tipo di apparecchiatura radio menzionato sopra è conforme alla direttiva 2014/53/UE.
Il testo completo della dichiarazione di conformità UE è disponibile al seguente indirizzo Internet:
- Latvian (LV)** Ar šo Furuno Electric Co., Ltd. deklarē, ka augstāk minēts radioiekārta atbilst Direktīvai 2014/53/ES.
Pilns ES atbilstības deklarācijas teksts ir pieejams šādā interneta vietnē:

Lithuanian (LT)	Aš, Furuno Electric Co., Ltd., patvirtinu, kad pirmiau minėta radijo įrenginių tipas atitinka Direktyvą 2014/53/ES. Visas ES atitikties deklaracijos tekstas prieinamas šiuo interneto adresu:
Hungarian (HU)	Furuno Electric Co., Ltd. igazolja, hogy fent említett típusú rádióberendezés megfelel a 2014/53/EU irányelvnek. Az EU-megfelelőségi nyilatkozat teljes szövege elérhető a következő internetes címen:
Maltese (MT)	B'dan, Furuno Electric Co., Ltd., niddikjara li msemmija hawn fuq-tip ta' tagħmir tar-radju huwa konformi mad-Direttiva 2014/53/UE. It-test kollu tad-dikjarazzjoni ta' konformità tal-UE huwa disponibbli f'dan l-indirizz tal-Internet li ġej:
Dutch (NL)	Hierbij verklaar ik, Furuno Electric Co., Ltd., dat het hierboven genoemde type radioapparaat conform is met Richtlijn 2014/53/EU. De volledige tekst van de EU-conformiteitsverklaring kan worden geraadpleegd op het volgende internetadres:
Polish (PL)	Furuno Electric Co., Ltd. niniejszym oświadczam, że wyżej wymieniony typ urządzenia radiowego jest zgodny z dyrektywą 2014/53/UE. Pełny tekst deklaracji zgodności UE jest dostępny pod następującym adresem internetowym:
Portuguese (PT)	O(a) abaixo assinado(a) Furuno Electric Co., Ltd. declara que o mencionado acima tipo de equipamento de rádio está em conformidade com a Diretiva 2014/53/UE. O texto integral da declaração de conformidade está disponível no seguinte endereço de Internet:
Romanian (RO)	Prin prezenta, Furuno Electric Co., Ltd. declară că menționat mai sus tipul de echipamente radio este în conformitate cu Directiva 2014/53/UE. Textul integral al declarației UE de conformitate este disponibil la următoarea adresă internet:
Slovak (SK)	Furuno Electric Co., Ltd. týmto vyhlasuje, že vyššie spomínané rádiové zariadenie typu je v súlade so smernicou 2014/53/EÚ. Úplné EÚ vyhlásenie o zhode je k dispozícii na tejto internetovej adrese:
Slovenian (SL)	Furuno Electric Co., Ltd. potrjuje, da je zgoraj omenjeno tip radijske opreme skladen z Direktivo 2014/53/EU. Celotno besedilo izjave EU o skladnosti je na voljo na naslednjem spletnem naslovu:
Finnish (FI)	Furuno Electric Co., Ltd. vakuuttaa, että yllä mainittu radiolaitetyyppi on direktiivin 2014/53/EU mukainen. EU-vaatimusten mukaisuusvakuutuksen täysimittainen teksti on saatavilla seuraavassa internetosoitteessa:
Swedish (SV)	Härmed försäkrar Furuno Electric Co., Ltd. att ovan nämnda typ av radioutrustning överensstämmer med direktiv 2014/53/EU. Den fullständiga texten till EU-försäkran om överensstämmelse finns på följande webbadress:

Online Resource

http://www.furuno.com/en/support/red_doc

ECF

(Elemental Chlorine Free)

The paper used in this manual
is elemental chlorine free.

FURUNO ELECTRIC CO., LTD.

9-52 Ashihara-cho,
Nishinomiya, 662-8580, JAPAN

• FURUNO Authorized Distributor/Dealer

All rights reserved. Printed in Japan

A : MAR. 2018

Pub. No. OME-72850-A

(MISU) SC-33



0 0 0 1 9 4 6 6 1 1 0